

# CHAPTER 1 SPECIFICATIONS AND SPECIAL PROVISIONS

## General Notes, Acronyms

### A. GENERAL NOTES

1. The City of Kannapolis Land Development Standards Manual has been adopted by the City of Kannapolis for use to design and construct infrastructure within the city limits of Kannapolis and the ETJ. The Manual is intended to provide the minimum specifications and standards for development. Additional requirements may be deemed necessary by the Director of Engineering, depending on the proposed improvement. There are supporting specifications from multiple agencies listed in Chapter 7 – REFERENCES. All specifications used and noted will be the most current revision for the respective specifications and publications. The more restrictive specification shall be enforced.
2. No work associated with excavations, tie-ins to existing utilities, lane or road closures requiring observation by City personnel will be allowed on weekends and holidays without authorization from the City Engineering Technician assigned to the project. The request to work on the weekend or holiday must be made 48 hours in advance.
3. No work will be permitted outside of the hours of 7:00AM to 9:00PM on weekdays and 8:00AM to 9:00PM on weekends without authorization from the Director of Engineering.
4. Contractors performing work in the City of Kannapolis shall have a North Carolina Contractor License with the appropriate classification for the work being performed.
5. No land disturbing activities shall be allowed until an erosion control permit has been obtained from the NCDEQ. Land disturbing activities include, but are not limited to, grubbing, grading and utility installations.
6. Prior to beginning construction in the City of Kannapolis, the contractor is responsible for obtaining all applicable local, state and federal permits. A preconstruction meeting with a City Engineering Technician shall be held, and submittals (shop drawings) shall be approved. The submittals should include all materials (roadway, storm, and utilities) to be used during construction. Please allow 10 business days for the review. The review will be performed by the Engineering Technician.
7. Erosion control measures shall be installed as required by the erosion control and sediment permit. Maintenance and documentation as required by the erosion control and sediment permit is the responsibility of the contractor and erosion control measures shall not be removed without the permission of NCDEQ or the Director of Engineering. Sediment leaving a site, regardless of size of project, shall have corrective actions taken immediately by the financially responsible person to avoid further loss of sediment from the site. Methods of conveyance of sediment from the site include water, air, gravity, or ice.
8. The use of City water to perform construction activities shall be metered. The City has one fire hydrant for obtaining non-potable water for construction located at the City's Operation Center, 1401 Bethpage Road. Prior to obtaining water from the hydrant, a permit application shall be submitted to the Water Resources Director. In lieu of using the fire hydrant at the City's OC, a fire hydrant meter may be obtained from the City for specific locations. For details to obtain a fire hydrant meter, contact City of Kannapolis Customer Service at 704-920-4444. The meter applicant is responsible for backflow prevention at the meter and payment for water used.

## B. ACRONYMS

**AASHTO** – American Association of State Highway and Transportation Officials

**ABC** – Aggregate Base Course

**ACI** – American Concrete Institute

**ANSI** – American National Standards Institute

**ASTM** – American Society for Testing and Materials

**CIP** – Capital Improvement Projects

**CRMPO** – Cabarrus-Rowan Metropolitan Planning Organization

**CTP** – Comprehensive Transportation Plan (Developed by the CRMPO)

**DIP** – Ductile Iron Pipe

**DWQ** – North Carolina Department of Environmental Quality, Division of Water Quality

**DWR** – North Carolina Department of Environmental Quality, Division of Water Resources

**FHA** – Federal Highway Administration

**IFC** – International Fire Code

**KDO** – Kannapolis Development Ordinance

**MUTCD** – Manual for Uniform Traffic Control Devices

**NACTO** – National Association of City Transportation Officials

**NCAC** – North Carolina Administrative Code

**NCDEQ** – North Carolina Department of Environmental Quality

**NCDOT** – North Carolina Department of Transportation

**NPDES** – National Pollutant Discharge Elimination System

**PROWAG** – Public Right of Way Accessibility Guidelines

**PVC** – Polyvinyl Chloride

**RCP** – Reinforced Concrete Pipe

**SCM** – Stormwater Control Measure

**USACE** – United States Army Corps of Engineers

**USGS** – United States Geological Survey

**WSACC** – Water and Sewer Authority of Cabarrus County

## CHAPTER 2 STREETS

### General Requirements, Standards of Street Design, Grading, Roadway Base, Roadway Intermediate and Surface Course, Sidewalks and Ramps, Driveways, Parking, Street Lighting, NCDOT Coordination, Retaining Walls, Bridges, Greenways

#### A. GENERAL REQUIREMENTS

1. All work and materials shall conform to the latest edition of the NCDOT Standard Specifications for Roads and Structures unless otherwise specified in this manual.
2. Depending on the proposed construction activities, a surety may be required for possible damage to City streets and shall be in an amount established by the City.
3. Street cuts and sidewalks should be completely repaired in an expedient manner. Unless otherwise noted in construction documents, cuts must be filled per Standard Details, with flowable fill or suitable material (asphalt, concrete or approved equal) to within 1.5" of finished grade within 3 days of initial work. Finished roadway surfaces, sidewalks and curbs must be restored within 30 days of initial work.
4. Contractor is responsible for keeping streets and driveways adjacent to the project free of mud and debris at all times. Contractor shall clean up and remove all loose material resulting from construction operations and shall take all available precautions to control dust.
5. **Subgrade Requirements:**
  - a. All subgrades shall be compacted to a depth of 8" below the finished surface to a 100% density in accordance with AASHTO T 99 as modified by NCDOT. All embankments shall be compacted to 95% density in accordance with AASHTO T 99 as modified by NCDOT for depths > 8".
  - b. All manholes, junction boxes, water valve boxes and other appurtenances shall be covered at subgrade level with a steel plate until the first lift of surface course asphalt is placed. At that time, the utility may be raised to the finished grade.
  - c. A tolerance for grading the subgrade shall be  $\pm \frac{1}{2}$ " from the established grade will be permitted after the subgrade has been graded to a uniform surface. A tolerance of  $\pm \frac{1}{4}$ " will be permitted under concrete pavement mainline lanes. Perform the grading operation such that the maximum difference between the established grade and the graded subgrade within any 100' section is  $\frac{1}{2}$ " for normal subgrade and  $\frac{1}{4}$ " for subgrade for concrete pavement.
  - d. A proof roll shall be required prior to placing curb and gutter, ABC, and asphalt. Equipment to be used for the proof rolls includes a loaded tandem dump truck or a loaded water truck.
  - e. Proof rolls will not be performed on frozen subgrades and inclement weather will void any proof roll if the associated work has not been completed.
  - f. A motor grader may be used in some circumstances for a proof roll on curb and gutter only. Prior approval by the Engineering Technician is required for use of a motor grader.
  - g. Weight requirements for equipment:
    - i. Motor Grader 30,000 lbs
    - ii. Water Truck 30,000 lbs
    - iii. Tandem Truck 45,000 lbs
6. **Concrete/Asphalt Placement Requirements:**
  - a. Concrete or asphalt shall not be placed in inclement weather. The contractor shall protect freshly placed concrete or asphalt in accordance with Section 420 (Concrete Structures), Division 6 (Asphalt Pavements), and Division 7 (Concrete Pavements and Shoulders) of NCDOT Standard Specifications. Prior to any concrete being placed, a pre-pour meeting shall be required. Schedule the pre-pour meeting with the inspector.
  - b. All concrete used for streets, curb and gutter, sidewalks, and drainage structures, etc. shall be approved NCDOT mixes, unless otherwise directed by the Director of Engineering or project special provisions. Concrete testing shall follow requirements and frequency set forth by NCDOT and ACI.
  - c. The concrete temperature at the time of placement shall be between 50°F and 95°F except where other temperatures are required by NCDOT Specifications, Section 420. Do not place concrete without permission when the air temperature measured at the location of the concrete operation in the shade away from artificial heat is below 35°F. When such permission is granted, uniformly

heat the aggregates and/or water to a temperature not higher than 150°F. Heated concrete shall be between 55°F and 80°F at the time of placement.

- d. All concrete curb and gutter shall be backfilled with soil approved by the Engineering Technician within 7 days after construction, but not before 3 curing days have elapsed. Do not place ABC or pavement adjacent to the curb before the 3 curing days has elapsed.
  - e. All excess concrete on the front edge (lip) of gutter shall be removed when curb and gutter is poured with a machine.
  - f. Straight forms shall not be used for forming curb and gutter in curves.
  - g. Contraction joints, expansion joints and joint sealer shall follow NCDOT Specifications and Kannapolis Standard Details.
  - h. All concrete shall be cured with curing compound. Use white pigmented curing compound which meets ASTM C 309, as required by NCDOT Section 825 and Section 1026, applied at a uniform rate per manufacturer's instructions. Apply the membrane curing compound after the surface finishing is complete and immediately after the free surface moisture disappears, but at no point, more than 24 hours of after placement of the concrete.
  - i. Prior to any asphalt being placed, a pre-pave meeting shall be required. Schedule the pre-pave meeting with the Engineering Technician.
  - j. Asphalt shall not be placed unless the minimum temperatures are met in NCDOT Specifications, Section 610. Do not place surface course material that is to be the final layer of pavement between December 15 and March 16 of the next year if it is 1" or greater in thickness, or between November 15 and April 1 of the next year if it is less than 1" in thickness, unless otherwise approved by the Engineering Technician. Do not place plant mix base course that will not be covered with surface or intermediate course during the same calendar year or within 15 days of placement if the plant mix is placed in January or February.
  - k. Drainage shall be maintained on the streets between the first lift of S9.5B and the final lift of S9.5B. Use Kannapolis Standard Detail 201 to accommodate drainage in low areas.
  - l. Surfaces shall be tacked when asphalt is being placed over existing asphalt streets or adjoining concrete, storm drain and sanitary sewer structures. In the event more than 1 lift of asphalt is placed in a single day, tack is still required between lifts.
  - m. All asphalt cuts shall be made with a saw when preparing street surfaces for patching or widening strips. Milling is an acceptable alternative to saw cuts when applicable.
  - n. Paper joints shall be used to seal the ends of an asphalt pour so that future extensions can be made without causing rough joints.
  - o. When placing asphalt against existing surfaces, a straight edge shall be used to provide a smooth and consistent transition between the two surfaces at that location.
7. **Trench Backfill Requirements:**
- a. All backfill shall be non-plastic in nature, free from roots, vegetative matter, waste, construction material or other objectionable material. Materials deemed by the Inspector as unsuitable for backfill purposes shall be removed and replaced with select backfill material.
  - b. All trenches in the street right-of-way shall be backfilled immediately after the pipe is laid. No more trench than necessary shall be opened in advance of pipe laying. One block or 200' (whichever is less) shall be the maximum length of open trench on any line under construction. All fill shall be placed and compacted in 6" layers.
  - c. All trench backfill, subgrade, embankment fill, and ABC shall require density tests be performed at a frequency as referenced in each respective section of NCDOT Specifications. Test reports shall be conveyed to the Engineering Technician on a weekly basis.
8. **Traffic Control, Striping, Signing:**
- a. The contractor shall maintain two-way traffic at all times when working within existing streets in accordance with the latest edition Manual for Uniform Traffic Control Devices (MUTCD) and NCDOT.
  - b. During phasing of residential developments temporary turnarounds are required for fire apparatus access. The temporary turnaround is required for streets 150' + from the intersecting street without a designed cul-de-sac.
  - c. All permanent striping shall conform to NCDOT Specifications, and MUTCD standards and specifications. Temporary striping may be paint and conform to NCDOT specifications for the duration of time in which the striping can be installed prior to installing the permanent striping.

- d. Dead-end streets without cul-de-sacs shall be required to install object signs designating the dead-end.
- e. Traffic Calming Devices are prohibited unless approved by the fire code official (ref current edition NC Fire Code).
- f. All street signage on publicly and privately maintained roadways shall be purchased from the City of Kannapolis. Contact the Planning Department for the street sign quote and payment.

## B. STANDARDS OF STREET DESIGN

1. **Streets** (Public and Private): Refer to Appendix A for Street Classifications.
2. **Intersections:**
  - a. Maximum Street Grade at Intersections (See Appendix A):
    - i. STOP or YIELD condition: vertical alignment is 2% maximum through the crosswalk areas (marked or unmarked). Outside of the crosswalk areas, the vertical alignment is 5% maximum within 100' of an intersection.
    - ii. THROUGH MOVEMENT condition: vertical alignment is 5% maximum through the crosswalk areas. Where feasible, it is recommended that the vertical alignment for a through movement street also be set at 2% maximum through the crosswalk areas (marked or unmarked).
    - iii. Insofar as practical, streets shall intersect at an angle of 90° for a minimum of 50' from the roadway intersection. In no case shall the angle be less than 75°. Intersections having more than 4 corners shall be prohibited. Proposed streets which intersect opposite sides of another street (either existing or proposed) shall be laid out to intersect directly opposite each other.
    - iv. A roundabout may be constructed at any intersection location where it may be desired to enhance intersection capacity, reduce vehicle speeds along a corridor, or enhance intersection aesthetics. Roundabouts shall be designed in accordance with the criteria set forth in Roundabouts: An Informational Guide (Federal Highway Administration Publication No. FHWA-RD-00-067). Care should be taken in order to ensure roundabouts are not located in close proximity to adjacent stop or signal controlled intersections where long queues may back up into the roundabout.
3. **Intersection Sight Distance:**
  - a. Minimum sight triangles shall be provided at each intersection corner to provide the driver an unobstructed view of the roadway.
  - b. Sight distance triangles shall be designed in accordance with Kannapolis Standard Detail 110.
  - c. Sight triangles shall contain no fence, structure, earth bank, hedge, planting, wall or other obstruction between a height greater than 2' above the property line grade as established by the Director of Engineering. The following may be exempted from this provision with approval from the Director of Engineering:
    - i. Public utility poles.
    - ii. Other plant species of open growth habit that are not planted in the form of a hedge and which are so planted and trimmed as to leave in all seasons a clear and unobstructed cross-view.
    - iii. Official warning signs or signals.
4. **Stopping Sight Distance:** stopping sight distances may need to be shown on the design plans. See Appendix A for minimum sight distances.
5. **Vertical Curves:** Provide vertical curves at grade breaks > 0.5. When designing intersection streets, low points should not occur in intersections. Design of vertical curves shall follow AASHTO design standards.
6. **Cul-de-sac Streets**
  - a. A maximum of 20 equivalent residential units (ERUs) may take access from a cul-de-sac. ERUs are determined in the KDO. Temporary cul-de-sacs on stub streets are exempted from this limitation.
    - i. The preliminary and final site plan shall show a stub connecting the cul-de-sac to adjoining areas or parcels where future roadways are delineated on a recorded subdivision or site plan (provided reasonable connection can be achieved without the need for a bridge or other

- feature to negate substantial topography). The stub shall be improved as pedestrian walkway, trail or bikeway.
- ii. The radius for the circular terminus, or turnaround, shall be not less than 48’.
7. **Stub Streets:**
    - a. All stub streets intended as a future connection to the adjacent property shall be properly signed to designate the future connection per Kannapolis Standard Detail 416.
  8. **Driveways**
    - a. See Chapter 2 Section G.
  9. **Design Vehicles**
    - a. Site designs and/or street designs shall evaluate the minimum turning radius for the vehicular traffic intended for use to support the proposed improvement. The evaluation of the vehicular turning radius shall include, but not be limited to, parcel delivery trucks, garbage trucks, semi-truck and trailers and current Kannapolis Fire Department fire apparatus vehicles. See Appendix A for appropriate design vehicles.
    - b. Regardless of the street classification or design vehicle, radii may need to be adjusted to meet the requirements of the proposed usage and vehicle. The Director of Engineering may request the additional requirements based on the proposed usage warrants.
  10. **A Traffic Impact Analysis:** A traffic impact analysis (TIA) may be required to identify impacts on the City’s roads from proposed development, and ensure those impacts are mitigated before or at the time the development occurs. The TIA will identify access improvements, near-site improvements, and on-site and off-site improvements that are needed to accommodate the proposed development and maintain the established level of service standards (LOS) on the roads in the City. Please see KDO Article 5 Chapter 13 for information on TIAs.
  11. **Turn lanes:** dedication and construction of turn lanes shall be required in any conditional use, special use, or driveway permit, or subdivision approval for a use or development which is adjacent to a two-lane public street with average daily traffic (ADT) exceeding 5000 vehicles per day (vpd), or a four-lane or larger public street with ADT exceeding 10,000 vpd, if any one of the following conditions are also present:
    - a. The use of development requires 50 or more off-street parking spaces.
    - b. The use of development consists of at least 50 attached or detached residential dwelling units.
    - c. The use of development will generate more than 100 trips during the peak hours of 7:00am-9:00am, 11:00am-1:00pm, and 4:00pm-6:00pm. Data shall be based on ITE’s “Trip Generation” and based upon the highest land use permitted by the zoning classification.
    - d. The use of development, as it may be affected by such restrictions, is reasonably expected to generate more than 25 truck (13,000 G.V.W.) trips per day through a single driveway.
    - e. The use or development, as it may be affected by such restrictions, creates special safety or traffic conditions due to limited sight distance and/or posted speeds more than 35 miles per hour along the adjacent public street. Such conditions shall be determined in writing by the Director of Engineering.

**TABLE A-1 STANDARDS OF STREET DESIGN**

Street Type		Alley	Local	Collector	Thoroughfare
Average Daily Traffic (ADT)		100	250	3000 Major 1000 Minor	8000 Major 4000 Minor
Longitudinal Grade	Min	1%	1%	1%	See Thoroughfare Plan
	Max: level/rolling	10 %	10 %	8 %	
	hilly	10 %	10 %	10 %	
	(stop/yield) at intersection	5 %	2 %	2 %	
	(through movement) at intersection	5 %	5 %	5 %	
Within 100' of an intersection		5 %	5 %	5 %	
Min Horizontal Centerline Curve Radius			150'	230'	
Min Tangent between Reverse Curves			50'	100'	
Street Intersection Radius <sup>(6)</sup>		20'	30'	30'	
Design Speed	Min	15 mph	25 mph	25 mph	
	Max	15 mph	35 mph	35 mph	
Design Vehicle		<b>Alley</b>	<b>Local</b>	<b>Collector</b>	<b>Thoroughfare</b>
	Residential	SU-30	SU-30	Bus-45 & SU-30	WB-62
	Non-Residential	SU-30	SU-30	WB-62 or WB-40	WB-62
Separation <sup>(1)(2)(3)</sup>	driveway - driveway	40'	40'	120'	400'
	driveway - intersection	25'	60'	120'	250'
	driveway - residential prop. line	5'	5'	5'	5'
	driveway - non-residential prop. line	10'	10'	10'	10'
	intersection - intersection	N/A	200'	200'	600'-1000'
Pavement Schedule <sup>(4)(5)</sup>		<b>Alley</b>	<b>Local</b>	<b>Collector</b>	<b>Thoroughfare</b>
	surface course (S9.5C)	2"	2-1" Lifts	2-1" Lifts	See NCDOT Roadway Design Standards
	intermediate course (I19.0C)	0"	2.5"	2.5"	
	base course (residential)	8" ABC or 4" B25.0C			
base course (non-residential)	N/A	10" ABC or 5" B25.0C			
Max Cul-de-sac Lengths	Zoning	R4, R8	AG, R1, R2	CD, LI, HI	MU, O-I, C-1, GC, PD
		800'	1000'	1500'	500'
	R18, CC				
	300'				
Dead-End Fire Apparatus Access Roads	Length	0-150'	150'-500'	500'-750'	750'+
	Width	20'	20'	26'	Special Approval Required
	Vertical clearance	13.5'	13.5'	13.5'	
	Maximum grade	10 %	10 %	10 %	
	Turnaround required	None	60" "Y" 96' ø Cul-De-Sac 120' Hammerhead (Temporary)		

Notes:

1. Single-family dwellings and duplex dwellings on individual lots shall be exempt from the minimum separation between driveways as shown in the table above. However, such driveways shall maintain a minimum of 5' of side clearance from residential property lines and 10' for all others.
2. City streets: proposed streets which intersect opposite sides of another street (either existing or proposed) shall be laid out to intersect directly opposite each other. Intersections which cannot be aligned shall be separated by a minimum length of **200'** between survey centerlines.
3. For state-maintained streets, reference the NCDOT Policy on Street and Driveway Access to North Carolina Highways.
4. Non-residential street pavement design shall be evaluated on a case-by-case basis.
5. Prior to substituting B25.0C, approval shall be obtained from the Director of Engineering.
6. Radius measured from edge of pavement.

## C. GRADING

1. The maximum slope for cuts and fill embankments is 3:1, unless authorized by the Director of Engineering. Fill embankment materials shall be placed and thoroughly compacted in successive layers less than 10" in depth for the full width of the cross-section, including the width of the slope area. No stumps, trees, brush, rubbish or other unsuitable materials or substances shall be placed in the embankment.
2. Longitudinal grades shall have a minimum grade of 1% and a maximum grade of 10%.
3. Transverse grade or crown shall be ¼"/ft.

## D. ROADWAY BASE

1. Stone base course shall conform in all respects to Section 520 (Aggregate Base Course), Section 1006 (Aggregate Quality Control/Quality Assurance), Section 1010 (Aggregate for Non-Asphalt Type Bases) of the NCDOT Standard Specifications for Roads and Structures.
2. The stone base shall be compacted to 100% in accordance with AASHTOT180 as modified by NCDOT when conventional density test #3 is used. When nuclear density testing is performed, a nuclear target density of at least 98% shall be obtained. In addition, the nuclear density of any single test location shall be at least 95% of the nuclear target density.
3. ABC will not be allowed within widening strips less than 5' in width.

## E. ROADWAY INTERMEDIATE AND SURFACE COURSE

1. Plant mixed asphalt shall conform in all respects to Section 610 (Asphalt Concrete Plant Mix Pavements) of the NCDOT Specifications for Roads and Structures.
2. A pre-pave meeting with the Engineering Technician shall be required prior to placing any asphalt.
3. An approved NCDOT Job Mix Formula shall be required to be submitted to the Engineering Technician for each mix to be used prior to paving.
4. The contractor shall have a QMS Roadway Technician on-site during the paving operation.
5. The final lift of asphalt surface course for residential subdivision streets shall be withheld until a minimum of 85% of the portion platted is occupied (occupied means a certificate of occupancy has been issued), or two years from recordation of the final plat. If, after two years from recordation, less than 85% of the development is occupied, the developer may be required to provide additional maintenance bonds.
6. After placement of the final asphalt, the Contractor may request final inspection for the roadway, and upon approval, the 1-year warranty of the roadway begins.
7. In the event construction traffic must be routed on newly paved streets, a bond shall be provided to the City until construction activities are completed.
8. Prior to placing the final layer of surface course asphalt, the Engineering Technician shall be given notice a minimum of two business days in advance to inspect the roadway for deficiencies. All deficiencies noted in the walk-through inspection shall be addressed prior to application of final layer.
9. Cores or nuclear density may be used on base, intermediate and first lift of surface course mixes. Cores will not be permitted on the final lift of surface course. Only nuclear density testing shall be used on the final lift of surface course.
10. Access must be maintained during the paving operation. Access for residents, emergency vehicles, solid waste collection and mail delivery will need to be addressed during the pre-pave meeting.

## F. SIDEWALKS AND RAMPS

1. Where sidewalks and pedestrian routes within street crossings (including marked and unmarked crosswalks) are provided, they must be constructed so they are accessible to all potential users, including those with disabilities and conform to Americans Disability Act and follow Public Right-of-Way Accessibility Guidelines.



2. Sidewalks shall be constructed of not less than NCDOT, Class B concrete, and shall be 4" thick, constructed on an adequately graded and compacted base, except where a sidewalk crosses a driveway or public easement access it shall be 6" thick. Subgrade shall be compacted to 95% of the maximum density obtainable in accordance with AASHTO T 99 as modified by NCDOT. The surface of the sidewalk shall be steel trowel and light broom finished and cured with an acceptable curing compound. Tooled joints shall be provided at intervals of not less than 5', and ½" expansion joints at intervals of not more than 50'. ½" expansion joints will be required where the sidewalk joins any rigid structure. The sidewalk shall have a maximum lateral slope of 2% toward the street.
3. All expansion joints shall be filled with joint sealer.
4. Planting strip adjacent to sidewalk shall be graded to ¼"/ft, except where excessive natural grades make this requirement impractical. In such cases, the Director of Engineering may authorize a suitable grade.
5. Sidewalk widths shall be a minimum of 5' unless otherwise specified.
6. A recorded public sidewalk easement is required for all sidewalks located outside public R/W; the width shall be equal to the distance from the right-of-way line to the back of the sidewalk plus two feet or to the face of building, whichever is less. The sidewalk easement must be recorded with the Cabarrus County or Rowan County Register of Deeds prior to issuance of a certificate of occupancy for the corresponding building(s).
7. Curb ramps are required where sidewalks intersect curbing at any street intersection and at Type III driveway connections. Running slope of directional ramps shall be a maximum of 1:12 (8.3%). If a 1:12 (8.3%) running slope is not achievable within 15 feet, the slope may exceed 8.3% and shall be uniform for the length of the ramp.
8. Truncated domes shall be Federal Standard Color Code number 20109, "Red Brown".
9. Refer to the MUTCD (latest edition) for construction zone pedestrian routes and signalization and controls for actuators. Curb ramps shall be designed and constructed in accordance with the American Disability Act.
10. Where pedestrian routes are contained within a street or right-of-way, the grade of pedestrian access routes shall not exceed 5%, or the general grade established for the adjacent street or highway.

## G. DRIVEWAYS

1. An approved Engineering Inspection Permit (Appendix A) from the City of Kannapolis is required prior to making a connection to a City street. Refer to the Kannapolis Standard details for driveway layout requirements.
  - a. Inspections of proposed street connections are required. Inspections shall be scheduled through Accela.
2. Depending on the type of connection to streets or roadways, additional right of way, dedicated to the City, may be required for improvements to the existing roadway. The cost of the right of way acquisition and street improvements are the responsibility of the Developer.
3. All driveway approaches shall be a concrete apron section, except that Type III driveway entrances may be required to public or private developments that have parking spaces for greater than 200 vehicles or when determined by the Director of Engineering. They shall be installed to the right-of-way line or at least 10' from the edge of the roadway and/or back of curb.
4. Medians or islands may be permitted for street type driveways and private street entrances only, upon approval of the Director of Engineering and subject to the following conditions:
  - a. The raised median or island shall be constructed on private property to the rear of the right-of-way line.
  - b. The minimum width of the median or island as measured nearest the right-of-way line (excluding the nose) shall be 15', the minimum length shall be 50'.
  - c. For street type driveways with a median or island, the combined width of pavement of the separated driveway segments shall not exceed 48'.

## H. PARKING

1. Off-street parking spaces shall be provided in accordance with the requirements in the KDO. The Planning Department reviews and approves the parking requirements and the Planning Director shall be authorized to approve any alternate parking plans for developments.
2. Parking spaces for handicapped or disabled persons shall comply with Chapter 4 of the North Carolina Accessibility Code and the following:
  - a. Single non-van: 14' x 18' (9' width + 5' access aisle).
  - b. Single van: 17' x 18' (9' width + 8' access aisle).
  - c. Double van, non-van, and van double: 26' x 18' (9' width for each space + 8' access aisle).
3. Reference Kannapolis Standard Details for parking dimensions.
4. Bumper Overhang dimensions for parking spaces include the front/rear of the parking space.
5. Parking lot drive-isle widths are measured from edge of pavement to edge of pavement.

## I. STREET LIGHTING

1. **Requests for Street Lighting:** Requests for street lighting may be submitted to the Engineering Department. Each request will be considered in accordance with approved standards and any special conditions of merit such as pedestrian activity, traffic volumes, accident history, crime rate, vertical and horizontal street alignment, and hazardous traffic conditions. Any extensions of the lighting system will be subject to the limitations of appropriation of funds by the City Council.
2. **Standards for Street Lighting**
  - a. Street lighting shall meet current engineering standards.
  - b. Light fixtures on public right-of-way for the purpose of illuminating the roadway by private citizens will not be permitted.
  - c. Private lighting fixtures mounted on the back of poles located on public right-of-way for the purpose of illuminating private property may be permitted with permission of the City of Kannapolis. All costs will be borne by the applicant and contractual arrangements made directly with the utility company.
  - d. The City of Kannapolis will not be responsible for any lighting fixtures installed for the purpose of illuminating private property.
  - e. A combination of street lighting fixtures and pedestrian lighting fixtures may be utilized to meet minimum lighting levels.
    - i. **Street lighting fixtures** shall be standard cobra head, minimum 110-Watt Roadway LED placed on twenty-five (25) foot metal. Street lighting on major thoroughfares may require higher wattage.
    - ii. **Pedestrian lighting fixtures** shall be mounted to a height of twelve (12) feet. The City reserves the right to approve or deny decorative lighting style options.
  - f. Where multiple street or pedestrian lights are required to meet lighting standards, lights shall alternate on both sides of the street.
  - g. Street and Pedestrian Lights shall be placed within the right of way on property lines unless approved by the City.
  - h. All new lighting shall utilize underground power.
  - i. The table below provides the required minimum levels of illumination (expressed in average maintained horizontal foot-candles).:

Street Classification	Illumination Levels (foot-candles)		Uniformity Ratio
	Commercial	Residential	
Major Arterial	1.3	0.8	3:1
Minor Arterial	1.6	0.8	3:1
Collector	1.1	0.6	4:1
Local	0.9	0.4	6:1
Alley	0.6	0.3	6:1
Sidewalk	0.9	0.3	6:1

**3. Lighting Plan Required**

For new development, a lighting Plan shall be prepared by a qualified lighting designer. Lighting plans shall be submitted to the City for approval along with subdivision utility plans in accordance with applicable City ordinances, policy and regulations.

**4. Lighting Installation Process**

- a. The lighting design is completed by the service provider and approved by the City of Kannapolis.
- b. Contract with service provider is signed by the City of Kannapolis.
- c. The customer responsibility / site readiness form is signed by the developer.
- d. Developer pays the full decorative adder fee to the Service Provider.
- e. Service Provider orders materials and installs streetlights per the approved lighting design.

**J. NCDOT COORDINATION**

- 1. Any connection or potential impact to a NCDOT roadway shall require approval by NCDOT. It is recommended coordination meetings take place early in the development process with the developer, NCDOT and City of Kannapolis discussing potential requirements for roadway improvements, access to the site and right of way dedications. NCDOT has the ultimate authority for any work in NCDOT right of way.
- 2. It is the sole responsibility of the requesting party to determine if a street is State maintained or not.
- 3. Plan submittals, review and approvals should be coordinated concurrently with both NCDOT and the City of Kannapolis, to avoid conflicting requirements. The coordination should consider the review process of the two agencies may not coincide and communication of submittals from the requesting party is essential in avoiding delays. In situations where an agency’s regulation differs from that of the other agency, the more restrictive of the two shall govern.
- 4. NCDOT and the City of Kannapolis require approvals for connections to existing roadways. The City of Kannapolis will approve any connections to City streets. Prior to obtaining Construction Plan approval, the requesting party shall provide the City of Kannapolis an approved driveway permit from NCDOT allowing access to the site from an NCDOT street.
- 5. During construction of the project, both NCDOT and the City of Kannapolis have enforcement authority to ensure safety in the right of way is not being compromised. Both agencies can affect the project’s progress if there is reason to believe proper construction practices are not being adhered to and/or if unsuitable materials are being used in the right of way. Failure to comply with permits and the approved plans may result in revocation of permits.
- 6. The City of Kannapolis has the authority to request that Cabarrus County or Rowan County Code Enforcement withhold the issuance of a Certificate of Occupancy until all work is completed and in compliance with the approved permits.

## K. RETAINING WALLS

1. Retaining walls or retaining wall systems providing cumulative vertical relief greater than 5' in height within a horizontal separation distance of 50' or less shall be designed under the responsible charge of a registered design professional per the latest edition of the North Carolina Building Code, Section 1807.2 and NCDOT retaining wall design guidelines. Allowable systems include but are limited to; cast-in-place walls, soil nailing, modular retaining wall system, mechanically stabilized earth (MSE) retaining walls, H-beam retaining wall system, boulder retaining walls and gabions. Design submittals shall include copies of foundation reports, design load assumptions, and retaining wall design calculations.
2. Building Permit approval and inspection of retaining walls shall be conducted by Cabarrus County or Rowan County Code Enforcement as applicable.
3. The developer is required to provide the approved wall designs to the City of Kannapolis prior to plan approval.
4. The developer shall be responsible for providing geotechnical testing, engineering oversight, and construction observation of wall construction by a qualified individual. Copies of the inspection reports and the design engineer's wall certification shall be provided with the as-built drawings for the retaining wall.
5. For retaining walls impacting City of Kannapolis easements, utilities, and right of ways, County approval of proper construction of the completed walls and completion of the City's Retaining Wall Certification form is required prior to the issuance of a Final Plat or Certificate of Occupancy, as applicable. If the retaining walls are used to assist with ingress/egress of City easements, the City will also be included in the approval process.
6. Cast in place concrete retaining walls are the only wall type that may be considered within the theoretical 1:1 of the roadway on a case-by-case basis.
7. When geo-grid is approved in the right-of-way and conflicts with a utility trench, the wall design shall include design calculations to allow the geo-grid to be interrupted within the utility trench. Clearances shall be provided between the geo-grid and conflicting utility to allow City personnel to maintain the utility without damage to the geo-grid or wall.

## L. BRIDGES

1. The use of a bridge for a publicly maintained project shall require prior approval by the Director of Engineering.
2. The layout and design of bridges shall follow the current applicable NCDOT policies and manuals and shall be designed under the responsible charge of a registered design professional.
3. The bridge shall be designed to include support for lighting, public water lines and other public utilities. Private utility lines are not allowed to be attached to the structure.
4. Design submittals shall include copies of foundation reports, design load assumptions, and bridge design calculations for structural components.
5. The developer shall be responsible for providing geotechnical testing, engineering oversight and construction observation of the bridge and associated structures by a qualified individual. Copies of the inspection reports and the design engineer's as-built certification shall be provided with the as-built drawings for the bridge.

## M. GREENWAYS

1. Greenways constructed in the jurisdiction of the City of Kannapolis shall follow current guidelines by NCDOT, NCDOT Greenway Specification Z-200, MUTCD, AASHTO, FHWA, ADA and include all required permits (e.g., NCDOT, FEMA Conditional Letter of Map Revision (CLOMR/LOMR), U. S. Army Corps of Engineers, DWQ, and NCDEQ).
2. Reference the AASHTO Guide for the Development of Bicycle Facilities for stopping sight distance design guidelines.
3. Horizontal radii shall be a minimum 90' centerline radius.
4. Radii at greenway intersections shall be a minimum 20' to accommodate maintenance vehicles.

5. Greenway intersections should be aligned at 90° angles when possible.
6. Shared-use trails shall be constructed to a minimum width of 10'. Trails to be used for pedestrians only shall be constructed to a minimum width of 5'.
7. Shoulders for all trails shall have a minimum 2' width on each side of the trail. 5' shoulders shall be required in fill areas and 3' shoulders in cut areas.
8. A clear, unobstructed, space from the edge of pavement of 10' shall be required. Trees greater than 15" in diameter may remain, provided they are at least 2' clear of the trail.
9. Greenways and trails shall not be constructed with a crown. All greenways and trails shall be constructed with cross-slopes between 1% - 2%.
10. Longitudinal slope shall be less than 5% unless existing contours prohibit. In the event grades are steeper than 5%, an 8.33% grade shall not be longer than 200', a 10% grade shall not exceed 30' and a 12.5% grade shall not exceed 10' without a rest area.
11. Rest areas shall be greater than 5' in length, have a width greater than the width of the trail segment to and from the rest area, have a grade less than 5%, have a cross-slope that exceeds 2%, have a minimal change of grade and cross-slope on the segment connecting the rest area with the main pathway and have accessible designs for amenities such as benches, where provided.
12. The typical section for greenways shall include:
  - a. Geotextile fabric for soil stabilization placed on subgrade compacted to a density of 92% in accordance with AASHTO T99 as modified by NCDOT.
  - b. ABC shall be placed at a 6" compacted depth with a density of 92% in accordance with AASHTO T180 as modified by NCDOT for both nuclear and ring test.
  - c. **Asphalt Option:** place asphalt, 2" of S9.5C placed in one lift, in accordance with Section 610 of the Standard Specifications, compacted to at least 85%. Coring of the final surface course will not be allowed.
  - d. **Concrete Option:** place 6" of Class AA concrete in accordance with NCDOT and ACI specifications. The concrete shall be reinforced with 6"x6"x1.4x1.4 WWF with non-structural fiber. The concrete will include ½" expansion joints at 40' spacing and control joints at 10' spacing.
13. Provide a 54" safety rail when the following is within 6' of the edge of pavement:
  - a. Slope ≥ 3:1 & drop of 6'
  - b. Slope ≥ 2:1 & drop of 4'
  - c. Slope ≥ 1:1 & drop of 1'
14. Retaining walls should be avoided but kept to a height of 4' or less where required.
15. The current North Carolina Building Code requires handrails where the distance from the top of boardwalk deck to the bottom of the creek/top of ground is ≥ 30". Where < 30", use a 6" toe board.
16. Bridges shall have at least 10' clear inside dimensions. For bridges 10' in width, a design load of H5 shall be required. For bridges 12' in width, a design load of H10 shall be required.
17. Overhead clearance shall be 8' minimum of vertical height for pedestrian trails and 10' of vertical height for multi-use trails.
18. During paving operations, dump truck loads shall be prohibited to 15 tons to prevent damage to the compacted ABC.
19. In environmentally sensitive areas, alternative seeding specifications may be required.
20. All public greenway entrances should provide removable bollards at entrances from roadways.
21. Public greenways may require safety and wayfinding signage as determined by the Director of Parks and Recreation.

## CHAPTER 3 STORMWATER

**General Requirements, Design Standards, Water Quality Design, Special Flood Hazard Areas, Pipe Types (RCP, HDPE, HPPP, CAMP), Special Structures, Pipe Inspections/Reports/Acceptance, SCM Estimates and Sureties, SCM Maintenance Agreements**

### A. GENERAL REQUIREMENTS

1. All work and materials shall conform to the latest edition of the NCDOT Standard Specifications for Roads and Structures, NCDOT Standard Drawings, the NCDEQ Minimum Design Criteria, the Kannapolis Development Ordinance (KDO) and the Kannapolis Land Development Standards.
2. Site grading shall not increase the volume or velocity of runoff onto downstream properties for the one-year and ten-year storm events, unless specifically approved as part of a project's drainage plan. Exceptions to this will be at the discretion of the Director of Engineering.
3. Prior to beginning construction in the City of Kannapolis, a preconstruction meeting with the City Inspector shall be held, and submittals (shop drawings) shall be approved. The submittals should include all materials (roadway, storm, and utilities) to be used during construction.
4. An operation and maintenance agreement and operation and maintenance plan shall be provided to the City for review prior to final platting.
5. **Stormwater Permit**

As provided in Article 5 of the KDO, The table below provides the minimum requirements for meeting the City's stormwater detention and water quality standards.

Site Condition	Stormwater Detention	Water Quality
< 1.0 ac & < 20,000 sf impervious area	See Note 1 below	No
< 1.0 ac & > 20,000 sf impervious area	Yes	No
> 1.0 ac & < 20,000 sf impervious area	Yes	Yes (low/high density)
> 1.0 ac & > 20,000 sf impervious area	Yes	Yes (low/high density)

**Note 1:**

If an existing site with less than 20,000 sf of impervious area is redeveloped, the applicant must provide detention for new impervious areas that create more than 20,000 sf of combined existing and proposed impervious area. If an existing site exceeds 20,000 sf of impervious area, stormwater detention for all proposed impervious areas is required.

Example 1: A site has 5,000 sf of existing impervious area. The proposed development will add 10,000 sf of impervious area, totaling 15,000 sf. No stormwater detention is required.

Example 2: A site has 10,000 sf of existing impervious area. The proposed development will add 15,000 sf of impervious area, totaling 25,000 sf. Stormwater detention is required for the proposed 15,000 sf.

**6. Access and Maintenance Easements**

All storm drainage structures and piping shall be located within the public right of way or within a storm drainage easement identified on the final plat.

- a. Minimum of 20' wide, pipe centered in easement preferably in common open space.
- b. Width requirements based on pipe depth (see Appendix A) and must provide for 1:1 excavation, bottom width = outside pipe diameter + 2'.
- c. Width requirements for channels should accommodate a minimum 10' wide path for maintenance vehicles.
- d. SCM Access & Maintenance easements may be a minimum of 10' wide and must connect to a public right of way.
- e. Shall be dedicated to the City of Kannapolis.
- f. Maximum slopes for maintenance vehicles: longitudinal = 15%, cross slopes of 5%.
- g. See LDSM details for overlapping easements.

7. **Stormwater SCM Embankments in the 100-yr floodplain**

SCM embankments located in the 100-yr floodplain must have a licensed engineer certify the fill elevation, compaction, slope, and slope protection materials. See Appendix A for certification form.

8. In areas where downstream impoundments will create a tailwater that backs water up into the pipe system, culverts shall be constructed with O-ring seals in the joints, which may require testing of the system. Locations of the system testing will be determined by the Director of Engineering.

9. **Storm Drainage Pressure Testing**

When pipe testing is required, the storm structures shall also be tested as required. Vacuum testing may be used as outlined in ASTM C1244. Exfiltration tests may also be performed as follows:

- a. Plug the inlet and outlet and fill the manhole with water to within 6.0' of the top of the manhole.
  - b. Allow the water to stabilize for 1/2 hour and refill the manhole to the original elevation.
  - c. Mark the initial depth of water, and after 1 hour record the drop in the water level in the manhole.
  - d. The maximum allowable drop in vertical water height in the manhole shall be 1/4" for all diameter sizes of manholes. If the water level in the manhole drops below the allowable drop amount, the Contractor shall repair the leak and retest.
  - e. Storm drainage piping shall be placed in a straight alignment at uniform grade. No changes in alignment shall be allowed except at catch basins, manholes, or other junctions that provide appropriate clean out access. The maximum length between access points is 400'.
  - f. Density tests shall be required on trench backfill at a frequency established in the NCDOT Specifications. Test reports shall be conveyed to the City on a weekly basis.
10. Precast waffle boxes may not be used in areas with traffic bearing loads. Pipe shall enter precast waffle boxes in the area provided for knock outs, the corner or supporting wall section of a waffle box shall not be cut.
11. All graded creek banks and slopes shall be at a maximum 2:1 and not to exceed 10' without terracing, otherwise the slopes shall be designed by a Professional Geotechnical Engineer and approved by the Director of Engineering on a case-by-case basis.
12. Acceptance of the storm requires: 2 videos (the 1<sup>st</sup> video is prior to the first proof roll, the 2<sup>nd</sup> video is after the installation of dry utilities, but prior to acceptance of the streets); as-built drawings; and certification by the design engineer using the Certification Form in Appendix A.
13. For pressurized systems, use O-ring culverts.

## B. DESIGN STANDARDS

1. **Stormwater Drainage Network Standards:**

- a. The City of Kannapolis has adopted the Charlotte-Mecklenburg Stormwater Design Manual for the design and evaluation of storm water management facilities. Storm drainage design shall conform to the standards and specifications provided therein except for flood analysis, approximate flood limits, and detention facilities used for credits.
- b. Site grading and construction shall not increase the flow rate or velocity of runoff onto downstream properties.

2. **Inlets and Catch Basins**

- a. The interior surfaces of all storm drainage structures shall be pointed up and smoothed to an acceptable standard using mortar mixed to manufacturer's specifications.
- b. All pipes in storm drain structures shall be flush with the inside wall. The floor of all storm drain structures shall be filled with concrete to an elevation flush with the downstream invert.
- c. All storm drain structures over 3'-6" in height must have steps in accordance with standard details set forth in NCDOT Standard Specifications for Roads and Structures.

- d. Catch basins, junction boxes, and storm drainage manholes shall be sized for the number and angle of pipes entering the structure. The following structures & non-standard structures require a PE's certification:

STRUCTURE	HEIGHT*
Brick catch basins	> 12'
Precast catch basins	> 16'
Open throat catch basins	> 16'
Drop inlets	> 12'
Junction Box	> 12'
Precast waffle wall structures	> 10'
Traffic bearing precast structures	> 15'
Precast manholes	> 30'
Brick manholes	Not Allowed

*Refer to the NCDOT Roadway Standard Drawings for the location of the measurement points to determine maximum height.*

- e. Catch basins with frame, grates and hoods installed in curb and gutter sections less than 2'-6" wide shall offset the frame, grate, and hood to the back of the structure to maintain a consistent width of roadway.
  - f. Frames, grates, and hoods shall not be offset from the catch basin more than 4", front to back.
  - g. Inlets shall be located using a rainfall intensity of 4"/hour, maximum 400' spacing.
  - h. Spread in a travel lane should not exceed 8' in a standard curb and gutter section.
  - i. Double catch basins shall be provided at all sag points.
  - j. No curb overtopping may occur in sags.
  - k. Catch basins shall be placed at lot lines to avoid conflicts with driveways.
3. Pipes and Culverts
- a. Construction plans shall include profiles and hydraulic grade lines of all pipe systems greater than 15".
  - b. Minimum pipe size is 15".
  - c. Storm system pipes shall be designed for non-pressure conditions using the 10-yr, 24-hr storm event.
  - d. Storm system pipes under roadways shall be designed for a 25-yr, 24-hr storm event. Storm system pipes under thoroughfares shall be designed for a 50-yr 24-hr storm event. Minimum pipe size crossing under roadways is 18".
  - e. Storm drainage pipe cover is a minimum 2.0'. For maximum cover, reference NCDOT Highway Design Branch Roadway Design Manual.
  - f. Provide hydraulic gradeline (HGL) calculations for the design storm. Minor losses are to be included in the evaluation and the HGL must be a minimum of 6" below the surface inlet elevation. Stormwater report must clearly show minor losses have been calculated. SCM water surface elevation shall be used as the tailwater condition for all storm sewer HGL determinations.
  - g. Drainage area maps for each catch basin shall be provided.
  - h. Minimum pipe slope is 0.5% or that which produces a velocity of 2.5 fps when flowing full.
  - i. Maximum pipe velocities shall not exceed 20 fps.
  - j. Maximum discharge velocities at pipe outlets shall not exceed 10 fps.
  - k. Influent and effluent pipe crowns shall match at junctions where the influent pipe diameter is smaller than the effluent pipe. At junctions where pipes are the same size, a minimum 0.2' drop shall be provided.
  - l. Pipe diameters shall not be reduced downstream.



- m. Storm drainage outfalls that run through lots shall extend to the rear lot line before daylighting.
  - n. Maximum headwater HW/D  $\leq$  1.2.
  - o. Minimum freeboard:
    - a. 12" for pipes  $\leq$  3'
    - b. 18" for pipes  $>$  3'
    - c. 6" at yard inlets
  - p. All connections to existing system(s) shall be engineered and shown on plans. Where tying into an existing system, the downstream receiving system shall be analyzed to the greatest extent practical for a determination of the ability to convey additional point discharges.
  - q. Outlet pipes shall be designed to provide non-erosive velocities leaving the storm sewer. Energy dissipation calculations shall be provided for all outfalls.
4. Open channels and Swales
- a. Channels shall be designed to convey the 10-year Design storm and such that the channel can convey the peak flow from the design storm without erosion, as demonstrated by engineering calculations.
  - b. Channels shall have a maximum side slope of 3:1
  - c. Channels shall have a minimum running grade of 2%
  - d. Minimum freeboard: 6"
  - e. Final design of open channels should be consistent with the velocity and shear strength limitations of the selected lining. Engineer shall provide all liner specifications and design information.
  - f. Channels with bottom widths greater than 10' must have a minimum cross slope of 12:1.
  - g. Rear yard drainage swales shall have a minimum distance of 10 feet from building foundations.
5. Low Density Design Standards
- a. Low density development shall be in compliance with 15 A NCAC 02H.1003.
  - b. Low density projects shall be designed to maximize dispersed flow through vegetated areas and minimize channelization of flow.
  - c. Stormwater that cannot be released as dispersed flow shall be transported by vegetated conveyances. A minimal amount of non-vegetated conveyances for erosion protection or piping for driveways or culverts under a road shall be allowed when it cannot be avoided. Maximum slope for low density development is 3:1.
  - d. The developer shall record deed restrictions and protective covenants prior to the issuance of a certificate of occupancy to ensure the development will be maintained in perpetuity consistent with the plans and specifications approved by the City.
6. **Stormwater Control Measure Standards:**
- a. All proposed site plans that require an NCDEQ Sediment & Erosion Control Plan, or that will exceed 20,000 sf in impervious area, shall be required to construct stormwater detention facilities to mitigate increased runoff. Calculations shall include:
    - i. Pre & post development drainage basin maps & hydrographs.
    - ii. If applicable, bypass runoff must be accounted for in calculations.
    - iii. Rainfall runoff intensities and depths for Cabarrus/Rowan county.
    - iv. Documentation for curve number, C values, time of concentration, and the equations used to generate the stage/storage/discharge tables.
    - v. Buoyancy calculations for the riser and uplift anchors.
    - vi. Detention facilities shall be designed to maintain the pre-developed runoff rate for 1-yr & 10-yr, 24-hr storm events.
    - vii. Emergency spillways shall accommodate the 50-yr, 24-hr storm event.
    - viii. Provide 6" of freeboard for emergency spillway.
  - b. Utilities are not permitted within impoundment areas.
  - c. Any orifice smaller than 4.0" in diameter must be protected to prevent blockage.
7. **Analysis of Existing Ponds**
- a. Existing ponds upstream of proposed development:
    - i. Provide jurisdictional determination of dam classification
    - ii. Provide approximate flood limits and elevations resulting from a dam breach using the 100-yr storm event

- iii. Set finished floor elevations at BFE +2'
- b. Existing ponds downstream of proposed development:
  - i. Provide jurisdictional determination of dam classification
  - ii. If the proposed upstream development increases runoff which impacts an existing pond, provide analysis of the pond using the 1-yr, 10-yr, and 50-yr storm event. Improvements to the pond may be required.

### C. WATER QUALITY DESIGN

1. The City of Kannapolis utilizes the State of North Carolina Department of Environmental Quality Design Manual for standards of design to obtain compliance to these requirements within the city limits or ETJ.
2. Alternate SCM designs may be used, but the products to be used must be part of the NCDEQ Preliminary Evaluation Period Program and include specifications for monitoring and replacement with an approved SCM if the product does not perform as designed.
3. Both point and non-point source pollutants shall be managed to comply with the Phase II NPDES Storm Water Permit requirements for post-construction pollution control. Reference the KDO for post-construction requirements.
4. All SCM embankments constructed must have a licensed engineer certify the fill elevation, compaction, slope, and slope protection materials.

### D. SPECIAL FLOOD HAZARD AREAS

1. The Planning Department regulates floodplain development. Please review Article 3.8.D of the KDO for floodplain development and permitting requirements.
2. The lowest finish-floor elevations for residential structures must be a minimum of 2.0' above the downstream road crossing elevation or 2.0' above the calculated 100-yr flood elevation. Areas with the potential to flood during the 100-yr event shall have no basement finished floor elevation lower than the downstream catch basin rim elevation, plus 2.0'. Slab on grade residential structures must be a minimum of 1.0' above the highest point of the downstream catch basin or yard inlet.
3. Flood studies documenting the impact of drainage structures to be constructed within a 100-yr floodplain are required. The culvert design capacity for these structures is the 100-yr storm event.
4. Flood Studies documenting the impact of fill placed in the 100-yr floodplain is required. See the KDO sections related to Flood Protection for additional guidance.
5. Flood Studies submittals should include digital files of the HEC-RAS models used to evaluate the impacts and a copy of the work maps used to prepare the study.
6. Plans should clearly label the existing and proposed conditions, the existing FEMA data, and the proposed ineffective areas, floodway modifications, revised flood fringe areas, and the revised 100-yr flood fringe.
7. Guidance for the Preparation of Flood Studies can be found in the following documents:
  - a. NC Department of Floodplain Mapping – Riverine Hydrologic & Hydraulic Engineering Guidelines and Standards.
  - b. FEMA – Procedures For “No-Impact” Certification for Proposed Developments in Regulatory Floodways.
  - c. FEMA – MT-2 Application Forms and Instructions for Conditional Letters of Map Revision and Letters of Map Revision.
  - d. FEMA – MT-1 Application Forms & Instructions Conditional Letters of Map Amendment (CLOMAs), Final Letters of Map Amendment (LOMAs), Letters of Map Revision Based on Fill (LOMR-Fs) and Conditional Letters of Map Revisions Based on Fill (CLOMR-Fs).
  - e. NCDOT – Guidelines for Drainage Studies and Hydraulic Design.
8. **100+1 Flood Analysis**
  - a. For areas located outside of the 100-yr floodplain, the 100+1 analysis may be required for all portions of a drainage system expected to carry  $\geq 50$  cubic feet per second for the 100-year storm event if the estimated runoff or proposed modifications to a storm water conveyance system would create a hazard for the adjacent properties or residents, as determined by the Director of Engineering.

- b. The 100-yr storm water surface elevations should be calculated using a method acceptable to the City as described in section 3.6 of the Charlotte Mecklenburg Storm Water Design Manual (Approximate Flood Limits).
- c. The peak flow rate used in the 100+1 analysis shall be based on an assumption of full build out of the tributary drainage area.

## E. REINFORCED CONCRETE PIPE (RCP)

1. All concrete shall meet the minimum specifications set forth in Section 1032 of the NCDOT Standard Specifications for Roads and Structures.
2. Concrete pipe used within the street right-of-way shall be a minimum of Class III Reinforced Concrete Pipe, with a minimum diameter of 15" (18" minimum on cross drain culverts within the ETJ and open-ended culverts under a road). Installation of Class IV or higher concrete pipe shall be identified on the as-built plan and the City inspector shall be given documentation and notification of this information prior to construction.
3. Use flexible plastic joint material except when material of another type is specified in the contract documents. Joint material of another type may be used when permitted.
4. RCP < 42" in diameter, NCDOT Section 300 shall be used for installation.
5. RCP ≥ 42" in diameter:
  - a. Wrap filtration geotextile fabric around all pipe joints. Extend geotextile at least 12" beyond each side of the joint. Secure geotextile against the outside of the pipe by methods approved by the Engineer.
  - b. #57 stone shall be used as bedding. Bedding shall consist of a minimum of 7" in depth under the pipe, continuing up to the spring line of the pipe.
6. ASTM C969 and ASTM C1103 are acceptable methods of testing concrete pipe when testing is required by the Director of Engineering.

## F. HIGH DENSITY POLYETHYLENE PIPE (HDPE)

1. HDPE pipe may be used outside the right-of-way.
2. The Product used shall be corrugated exterior/smooth interior pipe (Type S), conforming to the requirements of AASHTO Specification M294 (latest edition) for Corrugated Polyethylene Pipe and meet the minimum specifications set forth in Section 1032 of the NCDOT Standard Specifications for Roads and Structures.
3. Bell and spigot joints shall be required on all pipes inside the right-of-way. Bells shall cover at least 2 full corrugations on each section of pipe. The bell and spigot joint shall have an O-ring rubber gasket meeting ASTM F477 with the gasket factory installed, placed on the spigot end of the pipe. Pipe joints shall meet all requirements of AASHTO M294.
4. All HDPE pipe installed must be inspected and approved by the City's Inspector prior to any backfill being placed. The City inspector must be present during the backfilling operation as well.
5. Bedding for HDPE pipe shall be Select Material Class III or Class II, Type 1, loosely placed to a depth as outlined in NCDOT Standard Drawing 300.01, Flexible Pipe.
6. The minimum length of HDPE pipe permitted for use shall be 4'. HDPE flared end sections or fittings are not allowed.
7. All HDPE pipe installed shall be third party certified and shall bear the Plastic Pipe Institute's (PPI) certificate sticker.
8. All HDPE pipe shall be checked for deflection using a mandrel no sooner than 30 days after installation of the final backfill and prior to the final acceptance of the pipe. The mandrel size shall not be more than 5% of the inside diameter of the pipe, see Appendix A for dimensions of mandrel.
9. ASTM F1417 or ASTM 2487 shall be used when testing is required by the Director of Engineering.

## G. POLYPROPYLENE PROFILE WALL PIPE (HPPP)

1. The Director of Engineering may approve the use of HPPP for use both within and outside the right-of-way.

2. HPPP 12" – 60" dual pipe shall have a smooth interior and annular exterior corrugations; 30" – 60" triple wall pipe shall have smooth interior and exterior surfaces with the exterior having minor annular corrugations.
3. HPPP of the sizes shown or specified shall conform to:
  - a. ASTM F2736 Standard Specification for 6" - 30" Polypropylene (PP) Corrugated Single Wall Pipe and Double Wall Pipe
  - b. ASTM F2764 Standard Specification for 30" - 60" Polypropylene (PP) Triple Wall Pipe and Fittings for Non-Pressure Sanitary Sewer Applications
4. Submittals shall include:
  - a. Manufacturer's product information including details of installation, joints and pipe/manhole connections; properties and strengths of pipes; and instructions on storage, handling, transporting and installation.
  - b. Pipe design load calculations (suggested if deep burial is an issue).
  - c. Factory test reports.
5. Pipe shall be joined with a gasketed integral bell and spigot joint meeting the requirements of ASTM F2736.
6. Pipe diameters 12" - 60" shall be watertight according to the requirements of ASTM D3212, with the addition of a 15-psi requirement. Spigot shall have 2 gaskets meeting the requirements of ASTM F477. Gaskets shall be installed by the pipe manufacturer and covered with a removable, protective wrap to ensure the gaskets are free from debris. A joint lubricant available from the manufacturer shall be used on the gasket and bell during assembly.
7. 12" - 60" diameters shall have a reinforced bell with a polymer composite band installed by the manufacturer.
8. Damaged pipe will be rejected and shall be replaced at the Contractor's expense. Pipe and specials stored prior to use shall be stored in such a manner as to keep the interior free from dirt and foreign matter.
9. Fittings shall not be allowed. Any change in direction and/or additional pipes shall have a catch basin, manhole or junction box installed at the necessary location.
10. HPPP shall be installed within 6 months of delivery to project site unless written approval is granted from the manufacturer and approved by the Engineer. Approval of an extension in storage time must be requested in writing and accompanied by inspection within 2 weeks prior to installation by an authorized representative of the manufacturer.
11. Long-term above ground storage of HPPP and fittings shall conform to the following procedure:
  - a. Pipe shall be stored on flat timber supports to facilitate placement and removal of lifting slings around pipe. All pipes shall be chocked to prevent rolling in high winds.
  - b. If stacked, minimum 3" wide timber supports shall be used and placed at the quarter points with chocks. Pipe shall not be stacked higher than 10' above the ground.
  - c. Pipe and Fitting laydown should be relatively flat and free of other potentially damaging debris. Laydown area should have proper drainage. At no time, shall any portion of pipe or fittings be stored in standing water for more than 24 hrs.
12. Pipe shall be handled using textile slings or other means recommended by manufacturer. Chains and cables in direct contact with pipe are not recommended.
13. Installation
  - a. Shall be in accordance with NCDOT Specifications, Section 300, and ASTM D2321 and manufacturer recommended installation guidelines.
  - b. Minimum cover in traffic areas for  $\leq 48"$  shall be 1.0'
  - c. Minimum cover in traffic areas for  $\geq 60"$  shall be 2.0'.
  - d. Backfill material for minimum cover situations shall consist of:
    - i. Class 1
    - ii. Class 2: 95-85% SPD
    - iii. Class 3: 95-90%
    - iv. Class 4: 95%
14. Jointing:
  - a. Clean ends of pipe and coupling components.
  - b. Apply joint lubricant to pipe ends and elastomeric seals of coupling. Use only lubricants approved by the pipe manufacturer.

- c. Use suitable equipment and end protection to push or pull the pipes together.
  - d. Do not exceed forces recommended by the manufacturer for coupling pipe.
  - e. Join pipes in straight alignment. Do not allow any deflection angle or pipe misalignment to exceed the maximum permitted by the manufacturer.
15. Backfill
    - a. Use non-cohesive materials include gravels, gravel-sand mixtures, sands, and gravelly sands.
    - b. Accomplish immediately after the pipe is laid.
    - c. The fill around the pipe shall be placed in layers not to exceed 8".
    - d. Compacted to 95% of the maximum density with the AASHTO T 99 Modified Proctor Test.
    - e. A density of 100% AASHTO T 99 Modified Proctor is required for the top 8".
  16. Testing Polypropylene Profile Wall Pipe
    - a. Water tightness test (if required by the Director of Engineering) may be accomplished in accordance with ASTM F1417 or ASTM F2487.
    - b. Deflection shall be checked using a mandrel no sooner than 30 days after installation of the final backfill. The mandrel size shall not be more than 5% of the inside diameter of the pipe, see Appendix A for dimensions of mandrel.
  17. Provide properly trained manufacturer's service technician employed by the manufacturer to ensure proper installation of Polypropylene Profile Wall Pipe.

## H. SPECIAL STRUCTURES

1. Bridges, arch culverts, retaining walls, box culverts bottomless culverts, large headwalls, etc. shall be reviewed on a case-by-case basis depending on the intended use and environmental impacts associated with the project. The Director of Engineering shall set forth guidelines for the design of Special Structures.
2. All Special Structures shall be designed by a licensed professional with credentials to support the intended design and work.
3. All Special Structures shall follow the specifications, certifications and approval processes associated with Federal, State, and Local agencies, along with the requirements of this manual.

## I. PIPE INSPECTIONS, REPORTS, AND ACCEPTANCE

1. All storm drainage pipe installed in the right of way and/or easements require pipe video inspections submitted to the City of Kannapolis Engineering Department for review. Pipe video inspection shall be performed prior to roadway proof roll and prior to final street acceptance by the City
2. Remote inspection video equipment shall be able to accurately measure and verify crack widths as small as 0.05".
3. The pipe inspection report shall include the location, length, and width measurements of all cracks. Cracks shall be recorded to the nearest 0.50" for length and 0.05" for width.
4. The pipe inspection report shall include all pipe joint separations  $\geq 0.50"$ .
5. For longitudinal cracks having widths  $\geq 0.10"$  and  $\geq 3.0'$  in length, replace the pipe.
6. For circumferential cracks allowing entry of backfill, replace the pipe.
7. For multi-directional crack patterns where the damage extends over  $\geq 25%$  of inside circumference at a single location and crack widths  $\geq 0.05"$ , replace the pipe.
8. If infiltration or exfiltration is observed and the joint gap is  $< 0.75"$ , provide minor repair in method to be approved and field verified by the design engineer.
9. If the pipe joint gap is  $> 0.75"$ , replace the pipe.
10. For pipe with spalling that has exposed reinforcement, replace the pipe.
11. For flexible pipes with deflections  $> 7.5%$ , replace the pipe.
12. A new pipe video inspection shall be performed following repair or replacement of storm drainage pipes.

## J. SCM BONDS

Single family residential developments require SCM construction sureties which include a signed and sealed cost estimate from the design engineer. The surety serves as a means for the City to construct the SCM in its entirety in the event of the developer's default. The surety must be approved by the Engineering Director and issued to the City prior to recordation of the final plat. The following line items shall be included in the estimate for review and approval:

1. Contractor mobilization costs.
2. Complete SCM construction cost based on current average construction costs that would be incurred for the entire SCM, not a contractor's bid value for the project. Assume that any existing sediment basins must be reworked prior to the conversion of the basin into a permanent SCM. The value should include the cost of installing erosion control measures for the basin construction (e.g. construction entrance, silt fence, sediment basin pump out, and any other site-specific erosion and sediment control items required to construct the SCM).
3. Surveying costs for the as-built record drawing certifications.
4. Engineering costs for the as-built record drawing certifications.
5. Easement plat surveying for the plat dedication.
6. Easement acquisition costs including land value for the easement, attorney fees, and condemnation costs.
7. A contingency of 25% of total construction costs.

## K. SCM MAINTENANCE AGREEMENTS

Prior to the conveyance or transfer of any lot or building site to be served by a structural SCM in accordance with section 5.10 of the KDO, and prior to issuance of any permit for construction, development, or redevelopment requiring a structural SCM, the applicant or owner of the site must execute an operation and maintenance agreement that shall run with the land and be binding on all subsequent owners of the site, portions of the site, and lots or parcels served by the structural SCM. Until the transference of all property, sites, or lots served by the structural SCM, the original owner or applicant shall have primary responsibility for carrying out the provisions of the maintenance agreement. See Section 5.10.F.2 of the KDO for general requirements pertaining to the agreement.

## CHAPTER 4 UTILITIES

### General Requirements, Public Water and Sewer Main Extension Permits, Water Distribution, Sewer Collection, Sewer Pump Stations, and Sewer Force Mains, FOG (Fats, Oils, and Grease)

#### A. GENERAL REQUIREMENTS

1. Specifications used in addition to this manual are City of Kannapolis Water and Sewer Extension Policy, Code of Ordinances Chapter 17 – Water and Sewer, NCAC, NCDEQ, NCDOT Standard Specifications for Roads and Structures and WSACC.
2. All water and sewer permits shall be obtained prior to beginning construction. Any piping installed prior to obtaining permits will not be accepted.
3. Public water extensions shall be accepted into public service prior to any combustible materials being delivered or vertical construction beginning on new construction sites.
4. Any size service installation related to a major subdivision plat or project will be made by the developer. Reference the most recent fee schedule.
5. Master meters for water are not permitted for use at multi-family facilities. Each structure is required to have the proper backflow prevention installed and be individually metered.
6. Casing pipe for boring and jacking operations shall be steel pipe and have a minimum yield strength of 35,000 psi. The casing pipe shall be sized using the table in Appendix A.
7. All materials to be used on publicly maintained infrastructure must be domestic made.
8. Valves are required on each side of the water main at designated stream, creek, or river crossings, perpendicular roadway crossings that exceed 60' or at any other priority location as required by the Director of Water Resources.
9. No laterals or services shall cross back through an existing utility easement or within a right of way.
10. No horizontal bends will be permitted for lateral lines between the tap and the cleanout.
11. All water mains greater than 8" in diameter shall be shown in profile view.
12. All RPZ's are to be located outdoors and within 5' of the water meter.
13. Water meters, fire hydrants, and backflow prevention devices shall be designed and constructed per City, WSACC, and NCDEQ standards.
14. All fire hydrants shall be public and connected to mains owned and operated by the City of Kannapolis.
15. All water mains that serve more than one structure shall be considered public and will be provided with an adequate easement to maintain the line.
16. All irrigation lines shall be metered separately from the domestic line.
17. Detail 301 - Typical Section Utility Layout depicts location of water and sewer mains and applies regardless of public or private roadway maintenance.
18. Maximum depth of cover for PVC pipe shall be limited to 15'. Ferrous material shall be provided for all proposed water and sewer system extensions that have a depth of cover exceeding 15'. Depth over 15' is discouraged. Depth over 18' is prohibited within the roadway right of way within 10' of a driveway connection.
19. Any utility cuts performed in City of Kannapolis streets shall be repaired using City of Kannapolis Standard Details.
20. All utility structures installed in existing streets shall require excavatable flowable fill concrete to be used as backfill to fill the voids between the structure and the walls of the excavation.
21. Density tests shall be required on trench backfill at a frequency established in the NCDOT Specifications. Test reports shall be conveyed to the City on a weekly basis.
22. A minimum notice of 2 business days is required to schedule testing or final inspections of utilities.
23. **Easements**
  - a. Minimum 20' wide, pipe centered in easement preferably in common open space.
  - b. Width requirements are based on pipe depth (see Appendix A) and must provide for 1:1 excavation, bottom width = outside pipe diameter + 2'.
  - c. Shall be dedicated to the City of Kannapolis.
  - d. Maximum slopes for maintenance vehicles: longitudinal = 15%, cross slope = 5%.
  - e. See LDSM details for overlapping easements.
  - f. Private utilities are not allowed inside public utility easements except by Encroachment Agreement.

## B. PUBLIC WATER EXTENSION PERMITS

All public water main extensions to the City of Kannapolis systems shall be permitted through the North Carolina Department of Environmental Quality (NCDEQ) by the City following City review. Designs shall be in accordance with The Standard Specifications for Water Distribution for the Water and Sewer Authority of Cabarrus County (WSACC) and The City of Kannapolis Water & Sewer Standards and Policies.

Required information includes:

1. NCDEQ Application for Approval of Engineering Plans and Specifications for Water supply Systems
2. Digital copy of design plans
3. Engineer's Report - Water Model
  - a. Water models shall be required for permitting and to verify sufficient flow and pressures for the proposed extension. The following items shall be included as part of the proposed water system model:
    - I. Summary of the flow test data used to create model.
    - II. A schematic of the proposed system with all nodes and pipes clearly labeled.
    - III. Model should show that average daily use plus minimum fire flow requirements will not drop the pressure below 20 psi anywhere in the system.
    - IV. To simulate the existing system, the connection to the existing system should be modeled using a reservoir and pump. The pump curve should be based on fire hydrant flow data. Pump Report should be provided.
    - V. A pipe summary table should be provided that includes the following:
      - a. Pipe label, length, and diameter.
      - b. "C" factor (maximum allowable "C" factor = 120).
      - c. Flow under average daily conditions.
      - d. Hydraulic grade (upstream and downstream).
      - e. Head loss per 1,000' of pipe.
  - b. A junction summary table should be provided that includes the following:
    - I. Junction label, elevation, and demand under average daily conditions.
    - II. Static head and pressure.
    - III. Residual head and pressure under average daily conditions.
  - c. A fire flow summary table should be provided that includes the following:
    - I. Junction label.
    - II. Available fire flow.
    - III. Available total flow.
    - IV. Residual pressure at the fire flow node.
    - V. Minimum system pressure junction.
    - VI. Minimum system pressure.

## C. PUBLIC SEWER EXTENSION PERMITS

All public sewer main extensions to the City of Kannapolis systems shall be permitted through the North Carolina Department of Environmental Quality (NCDEQ) by the City following City review. Designs shall be in accordance with The Standard Specifications for Wastewater Collection for the Water and Sewer Authority of Cabarrus County (WSACC) and The City of Kannapolis Water & Sewer Standards and Policies.

Required information includes:

1. City of Kannapolis Allocation Permit (See the most current version of the City of Kannapolis Wastewater Allocation Policy for more information)
2. NCDEQ Fast Track Sewer System Extension Application and all required attachments
3. NCDEQ Flow Tracking for Sewer Extension Form
4. WSACC Sewer Flow Acceptance Form
5. Digital copy of design plans



## D. WATER DISTRIBUTION

### 1. Water Distribution Piping Materials

Shall be either PVC or DIP:

- a. 2" - 4" PVC SDR 13.5, Class 315, ASTM D 2241, ASTM D 1784 cell classification 12454-B, ASTM D 1869.
- b. 6" - 12" PVC C900, DR 14, Class 200. The bell of the pipe shall be an integral thickness wall made monolithically with the pipe.
- c. 3" - 12" DIP, Class 350, ANSI/AWWA C151/A21.51.
- d. 16" DIP +, Class 250, ANSI/AWWA C151/A21.51.
- e. Water service piping shall be Type K Copper tubing, per ASTM B-88.
- f. End connections shall be compression. Copper services shall conform to AWWA C-800. See Appendix A.
- g. Ductile Iron pipe may be required for public water systems under privately maintained driveways and parking areas, regardless of depth.

### 2. Fittings for Water Distribution Piping

- a. ≤ 2", push-on PVC, ASTM D-3139, SDR-13.5, Class 315.
- b. 3" - 4", DIP Class 250.
- c. 6" - 24" DIP Class 350.
- d. 30" + DIP Class 250.
- e. Mechanical joint fittings shall be CI or DIP and conform to ANSI/AWWA C110/A21.10 or ANSI/AWWA C153/A21.53 for compact fittings.
- f. Fittings for water services shall be red brass containing 85% copper, 5% lead, 5% tin, and 5% zinc in conformance with ASTM B-62. Fittings shall be compression in accordance with AWWA C-800 and shall utilize a compression and/or the split clamp with tightening screw. Stab type fittings are prohibited.

3. All materials shall be new, manufactured either in the year that construction begins or the previous year.
4. PVC pipe shall be shipped, stored, and strung in a manner to limit its total accumulated exposure to sunlight and UV radiation to no more than 4 weeks.
5. Tracer wire is required to be taped to all water piping, including mains and services. Tracer wire shall be #12 plastic coated solid copper wire. Non-metallic location tape is required 1' above the water piping.
6. Water line installation requires staking for alignment, location, and elevation.
7. All mechanical joint fittings, gate valves and fire hydrants require restraining glands and appropriate thrust blocks unless otherwise noted.
8. Water mains shall be adequately anchored to resist thrusts that may develop at fittings and any other location where a change in flow direction occurs.

### 9. Tapping Sleeve and Valves

All connections to existing mains shall require tapping sleeve and valves:

- a. Valves 2" - 12", 200 psi working pressure, 400 psi testing pressure.
  - b. Valves 14" - 24", 150 psi working pressure, 300 psi testing pressure.
  - c. Tapping sleeves shall be cast iron or stainless steel 150 psi working pressure.
  - d. Split-type cast iron tapping sleeves shall be required for all taps where the new branch line is of equal diameter as the existing main being tapped. Stainless steel tapping sleeves shall be required on all existing asbestos concrete piping regardless of size.
10. Water services shall be installed 5' from the sewer lateral, on the up-hill side of the lateral. The service shall not exceed the center of the lot, measured equidistance between proposed lot lines. Service lines shall not cross back over an easement for sewer or water mains.
  11. Water services shall not be permitted in sidewalks or driveways or other pavements. Any services in conflict shall be capped at the main and a new service connected at the main and installed to the property line. Lateral lines shall not cross back over an easement for sewer or water mains.
  12. All water services shall be installed uniformly on both sides of the street. No bends allowed in lateral line between tap and meter.
  13. Water meters shall read in gallons.
  14. Fire hydrants shall have integral Storz nozzles. Hydrants are to be painted Safety Red with industrial enamel paint.

15. A minimum 3' of clear space shall be maintained around the circumference of fire hydrants, unless otherwise approved.
16. Water mains installed in cul-de-sacs shall maintain a straight alignment to the back of the cul-de-sac with a blow off installed at the termination point, located behind the back of curb.
17. **Water Main Pressure Testing**
  - a. All new water mains shall be pressure tested for leakage and disinfected prior to acceptance by the City of Kannapolis.
  - b. Water mains shall be tested prior to placing ABC, curb and gutter or asphalt.
  - c. Testing of the water main cannot be performed until the water main has been backfilled and a minimum of 7 days after the last thrust block has been poured.
  - d. A representative of the City of Kannapolis shall be present for all testing.
  - e. Pressure tests will be conducted without interruption for a period of 2-hr and no more than 5000' per section tested. The allowable leakage shall be in accordance with current AWWA C600 standards, as shown in the below modified formula:  

$$Q = 0.0068 \text{ DLN}$$
 Where:  
 Q = allowable leakage in gal/hr  
 D = nominal diameter of pipe in inches  
 L = length of section tested in feet, divided by 1000'  
 N = square root of average test pressure in psi
18. Unless otherwise noted, fire hydrants shall be in the closed position during testing.
19. Disinfection of water mains shall conform to the requirements of ANSI/AWWA C651-92, WSACC and NCDEQ.
20. All frame and covers on manholes and valve boxes installed during construction of the water system shall be solid and state the use of system, "WATER" on the cover. Use NCDOT Standard Drawing 840.54.
21. Where corrosion is deemed to be a serious problem, DIP shall be provided with cathodic protection or an internal/external encasement, lining, or coating appropriate for the pipe material and situation. Such encasements, linings and coating shall be manufactured or applied in accordance with the appropriate ANSI and AWWA standards.
22. **Requirements for Acceptance of Water Main System**
  - a. As-Built Record Drawings per submittal requirements in Chapter 6.
  - b. Engineer's Certification.
  - c. State approval.
  - d. Easements or Rights-of-Way dedicated to the City.
  - e. **Mi.Net System:** Water main extensions may require installation of infrastructure to support the Mi.Net system utilized by the City of Kannapolis. The type of equipment and locations of said equipment shall be coordinated with the Director of Water resources. The City of Kannapolis shall not be responsible for the cost of the additional equipment unless otherwise noted.

## E. SANITARY SEWER PIPE

### 1. Sanitary Sewer Piping

Shall be either PVC or DIP, see Appendix A:

- a. 4" - 15" PVC shall be Solid wall ASTM D3034, SDR 35, Cell Classification 12454B.
- b. 18" - 48" PVC shall be Profile wall ASTM F794 Stiffness PS46.
- c. All sizes DIP shall be Class 50.
- d. All sewers shall be designed and constructed to give mean velocities, when flowing full, of not less than 2.0 fps, based on Manning's formula using an "n" value of 0.013. Minimum slopes for piping are as follows:

Diameter of Pipe (inches)	Minimum Slope (feet per 100 feet)
6	0.60
8	0.40
10	0.28
12	0.22
14	0.17
15	0.15
16	0.14
18	0.12
21	0.10
24	0.08
27	0.07
30	0.06
36	0.05

2. PVC pipe shall be shipped, stored, and strung in a manner to limit its total accumulated exposure to sunlight and UV radiation to no more than 4 weeks.
3. All materials shall be new, manufactured either in the year that construction begins or the previous year.
4. Transitions between PVC and DIP shall be made with an Adaptor Coupling SWRxDIOD Harco PT #2834-080 or approved equal.
5. **Sanitary Sewer Pipe Testing**
  - a. Sewer mains shall be tested prior to placing ABC, curb and gutter or asphalt.
  - b. A representative of the City of Kannapolis shall be present for all testing.
  - c. A mandrel test is required on PVC piping no sooner than 30 days after installation of the pipe.
  - d. Pipe  $\leq 24"$ , low pressure air testing shall be used in lieu of exfiltration testing. Low pressure air testing shall comply with ASTM C828 for PVC pipe. See Appendix A for Air Test requirements.
6. Continuity tests shall be performed on all tracer wire installed on all utility systems.
7. **Sanitary Sewer Pipe Bedding**
  - a. PVC - #57 stone 6" under the pipe to 6" over the top of pipe.
  - b. DIP - #57 stone 6" under the pipe.
  - c. The bedding requirements are minimum depths and unsuitable soils may require additional stone be placed in the trench. In the event the undercut extends 2' or more below the bottom of pipe, the Director of Engineering shall determine the means and methods of remediation.
8. #57 stone is required on all sewer laterals; see Kannapolis Standard Details.
9. Tracer wire is required to be taped to all sewer piping, including mains and laterals. Tracer wire shall be #12 plastic coated solid copper wire. Non-metallic location tape is required 1' above sewer piping.
10. Laterals shall have a No-Hub cast iron cap with a stainless-steel No-Hub coupling at the clean out at the property line.
11. Commercial buildings with an allocated flow greater than 1,000 GPD and apartment buildings of six (6) units or greater shall have a minimum 4' diameter manhole in lieu of 6" WYE.
12. Laterals are to be installed uniformly on both sides of the street, and at an appropriate location to maximize the lowest elevation of the lot, but in no case, shall be installed in a location with an elevation higher than the elevation at the center of the lot. Lateral lines shall not cross back over an easement for sewer or water mains.

13. Clean outs shall not be permitted in sidewalks or driveways or other pavements. Any clean outs in conflict shall be capped at the main and a new lateral connected at the main and installed to the property line.

**F. SANITARY SEWER MANHOLES**

1. Manholes shall be constructed with precast bases as indicated in the details.
2. Inside drops shall be used for 8” – 12” diameter sewer unless indicated otherwise on the drawings.
3. Manhole inside diameters\* shall be as follows, unless otherwise directed by the engineer or noted on the drawings, according to the largest sewer pipe connected to the manhole:

Pipe Diameter	Manhole Diameter
8” – 16”	4’
18” – 36”	5’
39” – 54”	6’
54” +	8’

\*The minimum diameter of all drop manholes (inside or outside) shall be 5’.

4. Minimum invert elevation entering manhole shall be 0.20’ above exiting invert or top of invert out pipe minus diameter of the entering, whichever is greater.
5. Drop manholes shall be required on sewer entering a manhole at an elevation greater than 2’ above the manhole invert. Where the difference in elevation is less than 2’, the invert shall be filleted to prevent solids deposition.
6. The flow channel shall be made to conform as closely as possible in shape, and slope to that of the connecting sewers.
7. All connections to manholes shall require resilient connectors, conforming to ASTM C923, with stainless steel clamp, draw bolt and nut or “A” Lok. Connections to existing manholes shall be made by coring into the existing manhole wall and installation of a resilient connector.
8. The connecting pipe shall not protrude more than 2” inside the manhole wall.
9. All manhole components shall be designed to withstand an H-20 loading. All precast manholes installed in the NCDOT right of way shall be approved by NCDOT.
10. Concrete used in the manufacture of manholes shall be 4,000 psi minimum at 28 days, containing 4% minimum air content, cement at a rate of 564 #/cy minimum, and conform to ASTM C478, C890, C891, C923, C33, C494, and C260.
11. Manhole reinforcement shall conform to ASTM A615 grade 60 deformed bar, ASTM A82 or ASTM A185 welded wire fabric.
12. All joints between precast components shall be sealed with butyl rope no less than 14’ long. The external joint shall be wrapped with a polyethylene backed flat butyl rubber sheet no less than 1/16” thick and 6” wide applied to the outside perimeter of the joint.
13. Manhole steps shall be provided in all sections of the manhole and be aligned vertically on 15” centers. The bottom step shall be no more than 26” from the top of the bench in the base section. The step pull-out strength shall be 1,000 lbs. minimum in accordance with ASTM C478.
14. Manholes shall have a maximum of 12” of grade rings placed on the structure. All joints, including grade rings, shall be sealed with butyl sealant, rope, and sheet types.
15. All frames and covers on sewer manholes shall be solid and state the use of system, “SANITARY SEWER” on the cover. Use NCDOT Standard Drawing 840.54.
16. All frames shall be set on butyl sealant and wrapped with sheet butyl. All frames set outside of the roadway shall be bolted to the manhole with at least 2 bolts on opposing sides of the frame. Frames and covers located outside the roadway shall extend at least 2’ above grade unless otherwise noted. Any frames and covers located in roadways or shoulders shall conform to the slopes surrounding the frame and covers.
17. Manholes shall be protected from the 100-yr flood by either setting the frame and cover 2’ above the 100-yr flood elevation or installing a watertight frame and cover with a vent 2’ above the 100-yr flood elevation. Manholes shall be vented every 1,000’ or every other manhole, whichever is greater.
18. Vent pipes shall be Grade B, FY=35,000 psi, 3” diameter with a mesh stainless steel screen in the opening.
19. Manholes shall be installed at the end of each line, at all changes in grade, size, or alignment, at all intersections, and at distances not greater than 425’. Sewer mains greater than 425’ may be allowed at the discretion of the Director of Engineering.

20. Where corrosive conditions are anticipated, consideration shall be given to providing corrosion protection on the interior of the manhole.
21. **Sanitary Sewer Manhole Bedding:** manholes shall set on a minimum of 6" of #57 stone, in accordance with LDSM Standard Detail 333.
22. **Sanitary Sewer Manhole Vacuum Pressure Testing:** Sewer manholes shall be tested prior to placing ABC, curb and gutter or asphalt. A representative of the City of Kannapolis shall be present for all testing. A vacuum of 10" of mercury shall be placed on the inside of the manhole. Vacuum testing shall be performed on 100% of the manholes installed. For a passing vacuum test on sanitary sewer manholes, the vacuum cannot drop from 10" – 9" under the following:
  - a. 4' diameter manhole, < 60 seconds.
  - b. 5' diameter manhole, < 75 seconds.
  - c. 6' diameter manhole, < 90 seconds.
  - d. 7' diameter manhole, < 105 seconds.
  - e. 8' diameter manhole, < 120 seconds.
  - f. 10' diameter manhole, < 150 seconds.
23. **Requirements for Acceptance of Sanitary Sewer System**
  - a. Video of the sewer system (after installation of dry utilities but prior to acceptance).
  - b. As-Built Record Drawing per submittal requirements in Chapter 6.
  - c. Engineer's Certification.
  - d. State approval.
  - e. Easements or Rights-of-Way recorded and dedicated to the City.

## G. WASTEWATER PUMP STATIONS

1. Due to the ongoing costs of operation and maintenance and potential negative for environmental impacts, the City of Kannapolis maintains a policy that aims to minimize the need for pump stations, to the greatest extent practical, all new sanitary sewer design shall be by gravity flow. Pressurized flow for gravity sewers shall only be allowed with approval from the Director of Engineering. The Director will consider the following factors when determining if construction of a developer-funded pump station will be permitted:
  - a. The pump station can be eliminated by a project or combination of projects, all of which are included for funding in the approved 5-yr CIP.
  - b. The pump station can be eliminated by a project being done under a reimbursable program and the funds have been made available to the City.
  - c. The proposed pump station is at an appropriate location and has adequate capacity or expansion capacity to serve as a permanent or long-term facility and gravity service is cost prohibitive or not possible due to other circumstances.
  - d. The construction of the proposed pump station would include elimination of one or more existing pump stations.
  - e. The construction of the proposed pump station would facilitate significant progress toward the achievement of land use goals and strategies described by current, officially approved planning documents and no other reasonable options are available for service.
  - f. The receiving system must have available capacity to carry the proposed pump station discharge. Any upgrades required will be the responsibility of the Developer requesting the pump station.
2. All wastewater pump stations shall be designed by Professional Engineer licensed in North Carolina, comply with the NCDEQ, Minimum Design Criteria for the Permitting of Pump Stations and Force Mains and be permitted through NCDEQ.
3. Only non-clog pumps designed and manufactured for use in conveying raw, unscreened wastewater shall be permitted. The pumps shall be capable of handling a 3" solid and any trash or stringy material that can pass through a 4" hose. Pumps shall be designed for continuous duty.
4. The impellers shall have blades that are generally forward rounded or otherwise configured to avoid catching solids, trash, and stringy material.
5. Pumps shall have no less than a 4" diameter suction and discharge opening.
6. Multiple pumps shall be used such that the pump station is capable of conveying the peak hourly wastewater flow to its desired outfall location with the largest single pump out of service.
  - a. In duplex pump stations, the pumps shall be of the same capacity.

- b. If pumps in series are required to meet capacity or total dynamic head requirement, each set of pumps in series shall be viewed as a single pumping unit.
  - c. Priming pumps as well as any other auxiliary system that is required for pump functionality shall also be provided in multiple numbers.
7. Determination of pump capacity shall be based on development build out. For regional pump stations, pump capacity shall be based on the entire service area over the life of the pump station.
  8. The minimum allowable design daily wastewater flow to the pump station shall be historical potable water use, wastewater flow generation data; or established long-range wastewater planning criteria.
  9. The storage capacity for the pump station shall include 2-hr storage above the high-water alarm elevation at the peak flow rate.
  10. Pump capacity shall also be based upon the need to maintain a minimum velocity of 2 fps.
  11. Pump selection shall be based on total dynamic head versus capacity; static head requirements; friction head requirements; minor losses; pressure head at the junction of the existing force main; no cavitating; and maximized operating efficiency.
  12. System curves shall be generated and evaluated not only for present day conditions, but also for conditions that may exist over the expected lifetime of the pump station.
  13. The Hazen-Williams friction coefficient, C, appropriate for the force main pipe material and age of the force main shall be used, see Appendix A.
  14. Consideration shall be given to minimizing motor speed and the motor horsepower shall be at least 1.15 x what is required during the entire pump performance curve.
  15. Constant speed pumps shall be cycled such that the number of starts is minimized, and resting times are maximized to avoid overheating and overstressing of the pump motor.
  16. All pumps shall be UL or FM listed, hermetically sealed, air-filled submersible type, electric motor for operation at 460V, 3ph, 60hz power. Pumps shall be designed for use in electrically hazardous locations, general use in pumping sewage, and be provided with thermal overload protection and moisture detection system.
  17. A quick disconnect suction line shall be installed in the wet well, 1' above finished floor, extending above the finished grade of the wet well. The suction line shall be restrained joint DIP.
  18. A quick disconnect pump connection shall be required at the location designated by the Kannapolis Director of Water Resources.
  19. For City maintained pump stations, the land shall be deeded and recorded to the City of Kannapolis. The tract shall be large enough to accommodate the pump station, structures (including a 10' x10' outbuilding), emergency generator, parking, and maneuvering of maintenance vehicles, grading, ingress/egress to the site, and a security fence.
  20. All ports of entry to the pump station, structures, vaults, panels, etc. shall be lockable.
  21. The lift station shall be provided with adequate indoor and outdoor lighting to facilitate normal and emergency operation and maintenance activities during daylight and non-daylight hours. Outdoor/all-weather lighting (120V) with outdoor/all-weather switches shall be provided under the weather cover for electrical and/or SCADA panels installed outside.
  22. The security fence shall be chain link, 8' high, around the entire perimeter and have double-swing gates with a minimum clear opening of 18'. The size, layout, and configuration of the fenced area for the lift station site shall be sufficient to allow multiple vehicles to be at the station at the same time. The site shall be able to accommodate at a minimum a 6,000-gallon triaxle vactor.
  23. Roads for ingress/egress of pump stations shall be a minimum of 16' wide but will be evaluated on a case-by-case basis to adequately serve the pump station in any weather condition. Refer to greenway trail typical section detail for minimum pavement schedule. Surface may be asphalt or concrete.
  24. All structures shall be designed and constructed in complete compliance with all applicable state, local and federal codes as well as applicable Occupational Safety and Health Administration (OSHA) and National Fire Protection Association (NFPA) standards and display all applicable safety placards.
  25. Piping and valves shall be designed and installed per NCDEQ Minimum Design Criteria for the Permitting of Pump Stations and Force Mains.
  26. The site shall have a water supply. If municipal water is the source of potable water, a ¾" water service with a reduced pressure principle backflow prevention device is required inside the security fence and shall have 120V power provided for freeze protection. If municipal water is unavailable, a well shall be required to provide water. Wells shall be required to deliver 10 gpm at 40 psi and be marked as non-potable. A freeze-proof yard hydrant is required inside of the security fence.

27. All electrical systems and equipment shall be designed and installed meeting the standards of Underwriters Laboratories Incorporated (UL), National Electrical Manufacturer's Association (NEMA), National Fire Protection Association (NFPA), North Carolina State Building Code (NCSBC), National Electrical Code (NEC) and NCDEQ, Minimum Design Criteria for the Permitting of Pump Stations and Force Mains (MDCPPSFM).
28. Contact Kannapolis Director of Water Resources, (704) 920-4200, to obtain the current requirements for installation of telemetry and other instrumentation.
29. Stand-by power generation is required for pump stations. The stand-by power shall be fueled by natural gas, where available, or liquid propane, where natural gas is not available. The generator shall be sized to adequately supply the pump station with consistent power enough to operate the pumps and supporting accessories throughout a power outage. The generating unit shall be located in a building structure or otherwise protected from the weather elements and meet the minimum requirements per the NCDEQ, Minimum Design Criteria for the Permitting of Pump Stations and Force Mains.
30. Testing of all appurtenances associated with the pump station shall be performed per the NCDEQ, Minimum Design Criteria for the Permitting of Pump Stations and Force Mains and/or local specifications.
31. 3 hard copies & 1 digital copy of the Operations & Maintenance (O&M) Manuals shall be provided to the City upon start-up of the pump station. The manual shall be prepared using the criteria in the NCDEQ, Minimum Design Criteria for the Permitting of Pump Stations and Force Mains.
32. If the pump station will be maintained by the City, one spare pump for each type/model shall be provided for each type/model of pump installed and 4 spare floats. In addition, 1 spare ultrasonic transmitter or pressure transducer shall be provided as selected by the Director of Water Resources.
33. If the pump station will be maintained by the City and the design capacity is greater than 15,000 gal per day, a 10' x 10' storage outbuilding shall be provided on site within the security fenced area. The storage outbuilding shall meet all minimum respective county codes. The storage outbuilding shall have at least one standard door and one double door opening of at least 7'h x 5'w. The storage outbuilding shall be equipped with a vent ridge type vent in the roof line. The storage outbuilding shall be equipped with outdoor clasp type locks to accommodate a pad lock. The storage outbuilding shall be equipped with a fire extinguisher inside. The storage outbuilding shall have studs at least 16" on center for the walls and be constructed on slab for flooring. The storage outbuilding shall be installed as to protect against flooding and shall be out of the flood plain.
34. The 100-yr floodplain elevation shall be noted on the applicant's drawings. All above ground equipment, electrical controls, and access hatches shall be located at least 2' above the 100-yr floodplain.
35. Landscaping Requirements - The applicant shall provide landscaping for the lift station in accordance with the Kannapolis Development Ordinance. At a minimum, landscaping shall be compatible with the surrounding neighborhood. However, Leyland cypress and poplar trees are not allowed for pumping station sites. Holly bushes are the preferred bushes for screening. Screening is required if there are existing or proposed dwellings within 200'. Within the lift station fence line, the entire area shall be provided with an asphalt or concrete surface as shown in the greenway trail typical section detail minimum pavement schedule, unless the Director of Water Resources approves an alternative surface. City vehicles must be able to pull within 4' of the wet well without obstruction.
36. The site shall be graded to provide positive drainage away from the lift station wet well, mechanical and electrical equipment and appurtenances.
37. All check valves shall be installed in the horizontal position in an accessible location outside of the wet well inside an epoxy coated vault or manhole with adequate clearance for its removal.
38. Stations with a permitted design flow of 0.5 MGD and larger, shall require additional solids removal. The additional removal can be achieved by using grinders or mechanical bar screen. All pump stations regardless of permitted design flow shall have a rag basket or rack screen.
39. All hatches shall be of sufficient size that the largest piece of equipment may be removed with a minimum of 6" of clearance on all sides. Hatches shall be solid aluminum diamond plate with spring assist if more than 50 lbs of lifting weight is required. Hatches shall include recessed lifting handle, security lock pin, and factory installed safety slide bars to hold vertically open. All hatches shall be anti-slam.
40. The submersible pump wet well shall be equipped with an ultrasonic transmitter or pressure transducer as selected by the Director of Water Resources to provide depth measurements to the SCADA system.

41. Permanent flow metering shall be required at all lift stations. Flow monitoring and run-time reporting software and hardware will be required at all proposed lift stations. All stations shall be provided with flow meters in accordance with the following requirements:
  - a. Flow meters shall be electromagnetic type with 316 stainless steel metering tube sized to maintain velocities within the recommended range provided by the manufacturer over the full range of anticipated flows.
  - b. Flow meters shall be installed in an accessible location in the lift station dry well or outside within the fenced area inside an epoxy coated vault or manhole with adequate clearance for its removal.
  - c. The piping installation shall provide 5 diameters of straight pipe runs upstream and 2 diameters downstream from the meter, or additional lengths if required by meter manufacturer. Bypass piping shall be provided of equal or greater size than the flow meter piping with sufficient valving to allow the flow meter to be removed for maintenance without taking the station out of service.
  - d. Flow meter shall be equipped with a microprocessor based "smart" transmitter that can convert and transmit a signal from the flow tube with a 4-20 mA DC signal.
  - e. The flow meter shall have an integrated LCD readout capable of displaying flow rate and totalized flow. The LCD screen shall not be installed inside the confined space vault.
42. All lift station structures other than the wet well shall be provided with a means to remove accumulated water and wastewater from the structure. All floor and walkway surfaces and sloped such that water and wastewater drains to a designated sump area under the influence of gravity.
43. All structures shall have means to remove accumulated water with an appropriately sized drainage pipe draining to the wet well. The discharge for the drainage pipe shall be higher than the high-water level alarm and be equipped with a buck-bill/check valve. The drainpipe shall not allow backflow of wastewater and gases from the wet well into the structure.
44. There shall be a spare check valve supplied for every model installed at the lift station.
45. Pump Piping Requirements - Each pump shall be provided with separate suction and discharge piping systems designed in accordance with the following minimum requirements:
  - a. Suction and discharge piping shall be a minimum of 4" diameter unless approved by the Director of Water Resources.
  - b. Suction and discharge piping shall be sized to maintain velocities between 2' and 8' per second. Suction piping shall provide a minimum 5 diameters of straight, unobstructed (i.e. no flow disturbing fittings) run upstream from the pump.
  - c. Suction piping for all wet well mounted suction lift stations shall be schedule 40 stainless steel at a minimum.
  - d. Reducers required for connection to the suction connection flange on the pump volute shall be long radius, concentric reducing elbows.
  - e. The pipe and fittings shall have a minimum of 12" of clearance from any wall or floor and there shall be a minimum 36" clearance between the piping of each pump or greater if required by the pump manufacturer.
  - f. All exposed fittings whether inside or outside the lift station shall be flanged joint ductile iron fittings. Applicants shall provide appropriate restraining joints for all piping.
  - g. Flexible couplings shall be provided on pump discharge piping and common headers to facilitate construction as well as routine maintenance and replacement of valves, etc.
  - h. Except for submersible pumps, restrained couplings shall be provided at the suction and discharge nozzles for all pumps that can accommodate both angular and parallel misalignment to prevent the transmission of pipe strain to the pump volute and limit nozzle loading in accordance with the pump manufacturer's requirements.
  - i. Wet wells shall be coated with an approved product.
46. Valve Requirements - All lift stations shall be provided with sufficient valves to allow for proper operation and maintenance of the lift station during normal, peak, and emergency bypass conditions. Valves shall be suitable for use with raw, unscreened wastewater and shall be of a design suitable for its function, its installation location, as well as the normal and maximum operating pressures expected at the lift station.
  - a. A full-closing eccentric plug shut-off valve shall be provided on the suction (for wet/dry pit stations) and discharge piping of each pump.
  - b. An outside-lever, swing check valve shall be provided on the discharge piping of each pump, between the pump and the shut-off valve. Check valves shall be installed in the horizontal position to prevent the accumulation of debris on the back side of the flap that may prevent the valve from



- opening. Check valves shall be located so that all working parts are readily accessible including the top cover that is removed periodically for maintenance.
- c. Discharge piping shall be connected to using a meg-a-flange connector in the valve vault.
  - d. Valves shall not be placed inside the wet well.
  - e. All valves should be individually supported from below wherever possible. The use of flange supports that bolt directly to the valve flange are discouraged unless other means of thrust restraint are provided that limit the movement of the valve and potential damage to both the valve and support.
  - f. Valving shall be adequate to provide for all operating conditions, pump removal and replacement, bypassing, and equipment maintenance (i.e., flow meters, electrical components, phased construction, mechanical maintenance, etc.)
  - g. All valves shall open left, counterclockwise.
47. Discharge Valve Vault Requirements for Submersible Lift Stations - Submersible lift stations shall be provided with a concrete valve vault located directly adjacent to the wet well. Valve vaults shall be provided with the following design features:
- a. Valve vaults shall be constructed of epoxy coated precast concrete. All precast structures shall comply with ASTM C-478 at a minimum.
  - b. The minimum allowable interior size for valve vaults shall be 6' x 6' for lift stations with 4"-6" force mains and 8' x 8' for larger force mains.
  - c. Valve vaults shall be provided with a minimum 4' x 4' double leaf aluminum access hatch.
  - d. Manhole steps shall not be installed in valve vaults. An OSHA approved aluminum access ladder shall be installed from the access hatches to 1' above the floor inside the vault and extend 2' above the hatch when fully extended.
  - e. Provide at least 12" of clearance between valves and the wall.
  - f. Provide at least 36" of clearance between the valves for each pump discharge.
  - g. When vertical clearance is required, it shall be adequate for safe worker entry and exit without crouching.
  - h. All penetrations to be cast with watertight flexible boots meeting ASTM C-923.
  - i. The floor shall be tapered to an 18" x 18" x 12" sump pit.
48. Lift stations shall be provided with a system that allows for the removal and installation of the pumps and grinders without requiring entry into the wet well or manhole and with clear vertical access:
- a. Each pump and grinder shall be provided with a dual-guide rail system and lift-out chain section with guide cable.
  - b. Removal systems shall guide the pump or grinder system into its fully seated, operating position.
  - c. Both the guide rail and the lift-out chain shall be capable of withstanding the forces required to disengage the pump or grinder from the wet well or structure.
  - d. Both the guide rail and the lift-out chain shall be manufactured of type 304 stainless steel.

## H. SEWER FORCE MAINS

1. Force mains shall be designed per NCDEQ, Minimum Design Criteria for the Permitting of Pump Stations and Force Mains.
2. Pipe materials and specifications shall be selected based on the installation and operating conditions of the system and shall consider the following criteria:
  - a. Installation depth and overburden pressure.
  - b. Soil conditions and groundwater pressure.
  - c. Corrosion resistance from both external and internal sources.
  - d. Strength required withstanding internal pressures expected during normal operation as well as those resulting from hydraulic surges and water hammer.
3. Force mains shall be constructed of the following pipe:
  - a. Ductile iron pipe – DIP shall conform to ANSI/AWWA C151/A21.51 "Ductile Iron Pipe, Centrifugally Cast in Metal Molds for Water or Other Liquids."
    - i. The thickness and pressure class of DIP pipe shall be determined in accordance with ANSI/AWWA C150/A21.50 "Thickness Design of Ductile Iron Pipe."
    - ii. Fittings for DIP shall conform to ANSI/AWWA C110/A21.10 "Ductile-Iron and Gray-Iron Fittings, 3" - 48" for Water and Other Liquids" or ANSI/AWWA C153/A21.53 "Ductile Iron Compact Fittings, 3" - 24" and 54" - 60" for Water Service."

- iii. DIP force mains shall have mechanical, gasketed push-on type joints. or flanged if exposed. Restrained joint DIP may be used for anchoring purposes. Gaskets shall be in accordance with ANSI/AWWA C111/A21.11 Flanged DIP shall conform to ANSI/AWWA C115/A21.15
    - iv. Where corrosion is deemed to be a serious problem, DIP shall be provided with cathodic protection applied in accordance with the appropriate ANSI and AWWA standards.
  - b. Polyvinyl Chloride (PVC) materials used in the manufacturing shall conform to ASTM D1784.
    - i. PVC pipe shall conform to AWWA C900 or C905. The thickness and pressure class of PVC shall be determined in accordance with AWWA C900 or AWWA C905 but shall be a minimum or Pressure Class 200, SDR 14 or less.
    - ii. Force mains of PVC pipe shall have elastomeric gasketed push-on type joints in accordance with ASTM F477 "Standard Specification for Elastomeric Seals (Gaskets) for Joining Plastic Pipe."
    - iii. Mechanical joint DIP fittings conforming to ANSI/AWWA C110/A21.10 and C116/A21.16-98 shall be used for force mains 4" in diameter and larger.
    - iv. PVC pipe shall be shipped, stored, and strung in a manner to limit its total accumulated exposure to sunlight and UV radiation to no more than 4 weeks.
- 4. All force mains shall be identified with green plastic locator tape & black lettering identifying the pipeline as sanitary sewer. The tape shall be placed approximately 1' above the pipe.
- 5. Tracer wire is required to be taped to the force main. Tracer wire shall be #12 plastic coated solid copper wire.
- 6. Force mains shall be adequately anchored to resist thrusts that may develop at fittings and any other location where a change in flow direction occurs.
- 7. Testing of the force main cannot be performed until the force main has been backfilled and a minimum of 7 days after the last thrust block has been poured.
- 8. The hydro-static test pressure shall be 1.5 x the maximum pump operating head range, but not less than 100 psi. The test pressure shall be held a minimum of 2 consecutive hrs.
- 9. All valve boxes shall be labeled "Sewer".
- 10. All force mains shall be installed with a corrosion resistant internal lining. Lining shall be Protecto 401 ceramic epoxy or approved equal, unless otherwise approved by the Director of Water Resources. When the Director waives the force main internal lining requirement, pipes shall have a standard cement mortar lining except at the locations specified below where the corrosion resistant lining shall always be provided:
  - a. At all high points for a minimum distance of 100' in each direction.
  - b. At all locations where partially full conditions may exist or where the force main may be exposed to air during static or operating conditions as determined by a hydraulic model of force main, plus an additional 40' in each direction. Provide hydraulic model for review if requesting variance.
- 11. **Requirements for Acceptance of Sanitary Sewer Force Main System**
  - a. Video of the sewer force main system (after installation of dry utilities but prior to acceptance).
  - b. As-Built Record Drawings per submittal requirements in Chapter 6.
  - c. Engineer's Certification.
  - d. State approval.
  - e. Easements or Rights-of-Way recorded and dedicated to the City.

## I. FATS, OILS, AND GREASE (FOG)

### 1. Minimum Design Criteria for Grease Separation Devices (GSDs)

- a. GSDs shall conform to Chapter 10, Sec. 1003 of the North Carolina Plumbing Code, the City of Kannapolis Land Development Standards Manual, and the City of Kannapolis FOG and Sewer Use Ordinances when being designed and constructed and shall be installed in accordance with the manufacturer's instructions. The designer shall contact the Cabarrus County Construction Standards Department for all applicable plumbing permit requirements.
- b. All GSD plans and specifications shall be approved by the City of Kannapolis Engineering Department prior to installation.
- c. GSDs may be used in series to meet the required capacity pending approval by the City of Kannapolis Engineering Department.
- d. Under Sink GSDs
  - i. Under sink GSDs shall be permitted in instances where in-ground GSDs, whether interior or exterior, are infeasible, or when an exception has been approved by the director of water resources or his designee. Under sink GSDs may also be used in series with an in-ground GSD to provide the required capacity. Under sink GSDs shall not be used as the sole device.
- e. In-Ground GSDs
  - i. Gravity GSDs must provide for a minimum hydraulic retention time of 24 min at actual peak flow between the influent and effluent baffles, with 25% of the total volume of the grease interceptor being allowed for any food-derived solids to settle or accumulate and floatable grease derived material to rise and accumulate, identified hereafter as sludge pocket and grease cap.
  - ii. The formula used for calculating in-ground gravity grease interceptor size is as follows:

**Interceptor Size (gal) =**

*((gpm/fixture x total # fixture ratings of grease-laden waste streams)*

*+ direct flow from a dishwasher, can wash, mop sink (gpm)) x 24-min retention time*

Pipe Diameter	GPM/Fixture
0.5	0.8
1.0	5.0
1.5	15
2.0	33
2.5	59
3.0	93

Fixture Ratings of Grease-Laden Waste Streams	Rating
2, 3 or 4 compartment sink	1.0
1 or 2 compartment meat prep sink	0.75
Pre-rinse sink	0.5
1 or 2 compartment vegetable prep sink	0.25

For direct flow from dishwasher, can wash, and mop sink, use the following gpm values:

Dishwasher = 10 gpm

Can wash and mop sink = 6 gpm

**Example:** A restaurant has the following fixtures in their kitchen:

- (1) 3 - compartment pot sink, 1.5" waste drain, 1 pre-rinse sink, 1.5" waste drain
- (1) 1 - compartment meat prep sink, 1.5" waste drain
- (1) 1 - compartment vegetable prep sink, 1.5" waste drain
- (1) can wash (use 6 gpm)

Using the formula to size exterior grease interceptors:

Gallons needed for grease interceptor

$$\begin{aligned}
 &= [(15 \text{ gpm} \times [1 + 0.5 + 0.75 + 0.25]) + 6 \text{ gpm}] \times 24 \text{ min} \\
 &= [(15 \text{ gpm} \times 2.50) + 6 \text{ gpm}] \times 24 \text{ min} \\
 &= [37.5 \text{ gpm} + 6 \text{ gpm}] \times 24 \text{ min} \\
 &= 43.5 \text{ gpm} \times 24 \text{ min} \\
 &= 1,044 \text{ gallons}
 \end{aligned}$$

**use 1,000-gal interceptor size**

- iii. Hydromechanical GSDs shall be sized in accordance with Section 1003.3.4 of the North Carolina Plumbing Code.
- iv. GSDs greater than 500 gallons must be located exterior to the facility.
- v. Metal GSDs are not permitted for all new facilities or existing facilities required to upgrade due to inadequate GSD size and/or failure.
- vi. Exterior in-ground grease interceptors located in green space shall have manhole frames and covers encased in a 4' x 4' concrete pad. The concrete pad shall extend a minimum of 6" above finished grade and be maintained in such a way as to remain free of landscaping material.
- vii. Cleanouts must be provided as shown in detail 350A and 350B of this document.
- viii. GSDs shall not be located in ADA parking spaces.
- ix. For facilities with a drive-thru service, GSDs shall not be located within the required stacking, nor shall they be located between the order box and the pickup window.

**2. Oil Separation Devices shall be sized as follows:**

Facility Category	Minimum Functional Volume (gal)
Auto Repair/Vehicle and Equipment Maintenance Facilities	1000
Automatic Car Wash with Recycling	750
Automatic Car Wash without Recycling	1000
Manual Car Wash with Recycling	1000
Manual Car Wash without Recycling	1200

## CHAPTER 5 FIRE PROTECTION AND ACCESS

### General Requirements, Fire Protection Requirements, and Access Requirements

#### A. GENERAL REQUIREMENTS

Specifications used in this section are from the NC Fire Code and 15A NCAC Water Supply - Section .0900 Water Distribution Systems

#### B. FIRE PROTECTION REQUIREMENTS

##### 1. Fire Hydrants:

- a. Applicants shall install fire hydrants in accordance with Kannapolis Fire Department specifications and requirements.
- b. The City may contract with a developer to install fire hydrants as required, but in all cases, the full cost of providing for such hydrants shall be borne by the developer.
- c. Any hydrant connected to the Kannapolis water system constructed pursuant this subsection, shall constitute dedication to the Kannapolis Water Resources Department of such hydrant.
- d. All newly installed fire hydrants shall have a Storz connection and be 5-1/4" barrel hydrants. All foot valves shall be 5-1/4" diameter. Only 3-way hydrants shall be installed with steamer connections. All hydrants shall be delivered with a primer coat. After hydrant installation, the primer shall be touched up and then painted red with reflective top (2 coats).
- e. Fire hydrants shall be installed on minimum 6" water mains.
- f. **Fire Hydrant Spacing:** Hydrants shall be placed in all residential and commercial developments in accordance with the regulations provided by the North Carolina Fire Code and the City of Kannapolis Development Ordinance. Please contact the Kannapolis Fire Department to coordinate the placement and number of hydrants required prior to submitting plans for review.
- g. All newly installed fire hydrants shall be tested by the Kannapolis Fire Department, or the fire department in whose jurisdiction it is located. The Contractor shall request inspection through the City Inspector, who shall notify the Kannapolis Fire Department, upon completion of the system and its availability for testing. No vertical construction shall be allowed in the project area until the water system has been tested and approved unless otherwise allowed by the authority having jurisdiction

##### 2. Fire Protection Facilities

- a. **Connections:** Connections for fire protection systems shall be made in compliance with the City of Kannapolis Backflow Prevention and Cross-Connection Control Policy. Fire protection water facilities installed upon the owner's private property are for the use of the owner, and the Kannapolis Water Resources Department assumes no responsibility for such facilities. No water service, other than fire protection, will be taken from water mains intended to provide fire protection only. Metering may be required of systems that are run periodically for testing with the water going to waste. Notification of testing shall be given to the Fire Marshal a minimum of two business days prior to testing. Violation of this notification may require the installation of approved metering devices and appurtenances as specified by the City of Kannapolis. The City reserves the right to make necessary inspections to ensure compliance with these regulations. No pumps may be directly connected to the Kannapolis system.
- b. **Cold Water Meters - Fire Service Type Size 6", 8", and 12":** All meters shall fully comply with the AWWA specification C-703-79. Fire service meters shall consist of a combination of main line meter of the proportional type, having an unobstructed waterway of essentially the full pipe size for measuring high rates of flow, and a bypass meter of appropriate size for measuring low rates of flow. The meter shall have an automatic valve mechanism for diverting low rates of flow through the bypass meter. Meters must be approved by the National Fire Protection Association and listed by the Underwriters Laboratories. Loss in head not to exceed 4 psi.
- c. **Casing:** Main casing shall be either of copper alloy containing  $\geq 75\%$  copper or of cast iron protected by a corrosion resistant coating or other anti-corrosion treatment. Main-case connections shall be flanged. Flanges shall be of the round type, faced and drilled, and shall conform to ANSI B16.1, Class 125. Companion flanges are not required.
- d. **Registers:** Registers shall be straight reading type and shall read in cubic feet. Registers will be provided with a center-sweep test hand. Registers will be perma-sealed.

- e. **Automatic Valves:** The automatic valve shall be of a type suitable for the purpose. It shall close by force. The weight of the valve and any supplemental force imposed on it shall offer sufficient resistance to the incoming water to diver all small flows through the bypass meter until such time as the rate of flow through the meter is great enough to ensure efficient operation of the main measuring section. Test plugs must be comparable to meter size.
  - f. **Test Outlet:** A minimum 2" outlet shall be provided on the downstream side of the meter.
  - g. **Piping Sizes**
    - i. 3/4" - 2" piping shall be brass
    - ii. 3" - 10" piping shall be ductile iron (cement lined).
3. **Fire Service Requirements**
- a. **Residential Districts:**
    - i. The minimum size fire service water mains in residential developments shall be 6" looped or 8" dead-end main.
    - ii. Mains shall be designed to provide the following flow rates at 20 psi:
      - a. R1, R2, R4, R8, and R18 zoning: 1,000 gpm
  - b. **Non-Residential Districts:**
    - i. The minimum size of fire service water mains in commercial and multi-family developments shall be 8" looped or 12" dead-end main.
      - a. Mains shall be designed to provide the following flows at 20 psi:
        - b. AG zoning: 1,000 gpm
        - c. MU and O-I zoning: 1,750 gpm
        - d. C-1, GC, CD and LI zoning: 2,000 gpm
        - e. HI zoning: 2,500 gpm
        - f. All other districts: 1,500 gpm
    - ii. The minimum size fire service water mains in industrial developments shall be 12" looped. No dead-end mains are allowed in industrial developments.
  - c. **Individual Large Structures:** Individual large structures with life safety hazards or extra hazardous operations shall, where required, be provided with on-site hydrants and water mains designed to provide the required fire flow as determined by the ISO formula and the Kannapolis Fire Department.
  - d. **Exceptions:** Notwithstanding the foregoing, mains installed may meet minimum performance specifications for the expected demand upon the system in lieu of the minimum size requirement.
4. **Fire Service Construction Plan Requirements**
- a. All Fire service plans must be reviewed and approved by KFD.
  - b. Show ingress and egress fire truck turning movements through developments. Use a Bus-45 vehicle template to mimic a fire ladder truck.
  - c. FDC's are to be a minimum of 10' from the face of a building.
  - d. Proposed hose pulls from hydrants across any street must be reviewed and approved by KFD.
  - e. Fire truck turnarounds must be encompassed in dedicated R/W.

## C. FIRE SERVICE ACCESS REQUIREMENTS

- 1. See Chapter 2 – Streets for additional details.
- 2. **Separate Fire Access Road** is required:
  - a. # of dwelling units > 100 (exception: sprinklered developments)
  - b. Turnaround movement exceeds 150'
- 3. **Design Criteria:**
  - a. Width = 20' (26' w/ a fire hydrant)
  - b. Height clearance = 13.5'
  - c. Maximum grade = 10%
  - d. Capacity = 75,000 lbs
  - e. Provide positive drainage away from the road section
  - f. Turnaround type:
    - i. Turnaround lengths 150' – 750': 1) 60' "Y", 2) 96' diameter cul-de-sac, or 3) 120 hammerhead
    - ii. Turnaround length > 750' requires prior KFD approval

## CHAPTER 6 PLAN SUBMITTAL REQUIREMENTS

### Construction Plans, As-Built Record Drawing Submittal Requirements, Certifications, and Encroachment Agreements

#### A. GENERAL REQUIREMENTS

Ensure the following are included:

1. Plans submitted on 24" x 36" sheets to include vicinity map, north arrow, legend, datums, sheet index, match lines, scales, existing conditions, note of caution for underground utilities (811 logo), applicable notes from this section and all proposed improvements.
2. Plans and calculations shall be sealed by a licensed engineer in the state of North Carolina.
3. Copies of required permits & agreements (which may include, but are not limited to: US Army Corps of Engineers 401/404 Permit, NCDEQ Sedimentation & Erosion Control permit, NCDOT 3-Party Encroachment Agreement, NCDOT Driveway Permit, City of Kannapolis Water & Sewer Extension Permit, City of Kannapolis Utility Encroachment Agreement, Temporary Construction Easement, Impacts to/Encroachments upon Adjacent Properties).
4. For projects with intermittent and/or perennial streams, provide a copy of the NC DWQ Stream Identification Form (latest version) submitted to the NC Division of Water Resources. The report must be signed and include the certification number of the qualified individual certified to make legal determination of stream origins and identify surface waters in accordance with NCGS 143-214.25A(B) and KDO 3.8 H. (3). The lowest finish floor elevations for residential structures must be a minimum of 2.0' above the downstream road crossing elevation or 2.0' above the calculated 100-yr flood elevation. Areas with the potential to flood during the 100-yr event shall have no basement finished floor elevation lower than the downstream catch basin rim elevation, plus 2.0'. Slab on grade residential structures must be a minimum of 1.0' above the highest point of the downstream catch basin or yard inlet.

#### B. PLAN NOTES

##### Site Plan Sheet Notes:

1. The City of Kannapolis Land Development Standards Manual and NCDOT Standard Specifications are used for construction of the roadways, including the NCDOT SuperPave Manual.
2. Section 1018 of the NCDOT Standard Specifications will be used for the acceptance of borrow material being used for embankments backfill or other intended uses.
3. Contractor shall provide a minimum notice of two business days for scheduling any proof rolls. Adequate time shall be provided for the inspector to perform grade checks on the subgrade and ABC. A proof roll with a City of Kannapolis inspector shall be performed prior to:
  - a. Placement of ABC.
  - b. Placement of curb and gutter.
  - c. Placement of asphalt.
4. For NCDOT maintained streets and thoroughfares, the contractor shall contact NCDOT to confirm additional inspection requirements that may apply.
5. Aggregate Base Course shall be provided from approved sources as outlined in Section 1010 of the NCDOT Standard Specifications.
6. A Pre-Paving meeting shall be required prior to any paving. Contractor shall request a pre-paving meeting with the City Inspector a minimum of two business days in advance.
7. A NCDOT approved Job Mix Formula must be submitted to the City Inspector for approval prior to paving.
8. Asphalt mixes and depths will adhere to the typical section for roadways approved in the construction drawings. Minimum depths unless otherwise noted will be 2 ½" of I 19.0C placed in one lift and 2" of S9.5B placed in two lifts. The first lift of S9.5B will be placed immediately on the I19.0C, and the second lift will be placed prior to acceptance of the road. Drainage will be required on the roadway during the transition of the two lifts of S9.5B.
9. A Pre-Pour meeting will be required prior to any concrete pours. Contractor shall request a pre-pour meeting with the City Inspector a minimum of two business days in advance.
10. An NCDOT approved Mix Design must be submitted to the City Inspector on a NCDOT form 312U prior to placing any concrete.

11. Refer to detail sheets for the proper installation requirements for storm piping using NCDOT Standard Drawing 300.01.
12. The contractor shall be required to submit a video of the storm system prior to acceptance of the system. In new subdivisions, 2 videos of the storm system shall be required. The first video is required to be performed prior to the first proof roll. The second video is required after the installation of dry utilities, but prior to acceptance of the streets by the City of Kannapolis.
13. An Erosion Control Permit from the responsible compliance authority is required to be prominently displayed on-site during construction. For projects disturbing an area greater than one (1) acre, NCDEQ will have inspection and compliance authority. For all construction disturbing less than one (1) acre, the City will have inspection and compliance authority. All site activities shall be in compliance with the approved Erosion Control Permit.
14. The approved typical section includes a shoulder behind the curb and gutter on both sides of the roadway. The shoulder must be preserved during grading of adjacent properties.
15. Only street legal vehicles, legally loaded appropriately for the hauling vehicle, shall be used to transport construction materials on City streets.
16. The contractor must notify the City a minimum of two business days in advance of any work to be performed on the weekends or on City Holidays. No work requiring testing or observation by the City shall be permitted without permission from the City Inspector.
17. The City's Noise Ordinance prohibits work outside of the following hours: 7:00am to 9:00pm – weekdays, 8:00am to 9:00pm weekends. Contractor must notify the City a minimum of two business days in advance of work to be performed outside of these hours. No work outside of these hours shall be performed without permission from the City Inspector.

**Utility Plan Sheet Notes:**

1. All water and sanitary sewer work shall be in accordance with the City of Kannapolis Land Development Standards Manual, the NCDEQ Minimum Design Criteria for the permitting of Gravity Sewers, the NCDEQ Rules Governing Public Water Systems, and Standard Specifications for Wastewater Collection and Distribution for the Water and Sewer Authority of Cabarrus County (WSACC). Contractor shall always have a copy of these specifications on-site.
2. Per NC GS 8A 87-121 (g) all facilities shall be electronically locatable.
3. All fire hydrants shall be installed in accordance with the Kannapolis Fire Department specifications and requirements.
4. All newly installed fire hydrants shall Hydrants shall meet Kannapolis standard detail 321.
5. All newly installed fire hydrants shall be tested by the Kannapolis Fire Department, or the fire department in whose jurisdiction it is located. The Contractor shall request inspection through the City Inspector, who shall notify the Kannapolis Fire Department, upon completion of the system and its availability for testing. No vertical construction shall be allowed in the project area until the water system has been tested and approved unless otherwise allowed by the authority having jurisdiction.
6. Unless otherwise noted on the construction drawings, all existing water and sewer mains are owned and operated by the City of Kannapolis. The site inspector must be contacted at least two business days prior to making any connection to the existing system.
7. Sanitary sewer laterals and water meter locations are approximate and are subject to relocation due to field conditions. Under no circumstance will cleanouts or meters be located in driveways, sidewalks or under pavement of any type.
8. Water meters shall meet City of Kannapolis standards. Contractor is responsible for installing meter boxes and purchasing meters. Contractor shall coordinate with site inspector to have water meters delivered to the City of Kannapolis.
9. The developer will be responsible for paying applicable water and sewer connection fees before Zoning Clearance Permits are issued.
10. Contractor is fully responsible for contacting all appropriate parties assuring that utilities are located prior to commencement of construction. Call North Carolina 811 (1-800-632-4949) for utility locating services as required by law prior to commencement of any work. Contractor shall verify location and depth of all utilities prior to construction.
11. Contractor shall be responsible for sewer overflows that occur due to activities initiated by them and shall be responsible for, but not limited to, the costs associated with performing remedial work of/for environmental impacts and/or the paying of fines assessed by regulatory agencies and/or third-party claims.



12. Water & Sewer mains shall have a minimum cover of 36".
13. Bedding for PVC sewer mains and laterals should be WSACC class B bedding.
14. Unless otherwise noted, waterlines shall be PVC C900 for 6" - 12" diameter and PVC SDR 13.5 for 2" - 4" diameter per WSACC standards.
15. Unless otherwise noted, sewer mains shall be PVC SDR 35 per WSACC standards.
16. Laterals shall have a No-Hub cap and stainless-steel No-Hub band at the clean out.
17. Water mains shall be laid at least 10 feet laterally from existing or proposed sewers, unless local conditions or barriers prevent a 10-foot lateral separation, in which case:
  - a. The watermain shall be laid in a separate trench, with the elevation of the water main at least 18 inches above the top of the sewer; or
  - b. The water main shall be laid in the same trench as the sewer, with the water main located at one side on a bench of undisturbed earth and with the elevation of the bottom of the water main at least 18 inches above the top of the sewer.
  - c. Deviations to minimum horizontal separation must be approved by the City of Kannapolis and NCDEQ.
18. A water main that crosses a sewer or other non-potable waterline shall be laid a minimum vertical distance of 18 inches from the outside of the water main and the outside of the sewer, either above or below the sewer but, if practicable, the water main shall be located above the sewer. One full length of water pipe shall be located so that both joints will be as far from the sewer as possible. Deviations to minimum vertical separation must be approved by the City of Kannapolis and NCDEQ.
19. Ductile iron pipe shall be required for both water and sanitary sewer if the following clearances are not met:
  - a. Waterline crossing under sanitary sewer (for any clearance).
  - b. 18" vertical clearance for waterline installed above sewer line.
  - c. 10' horizontal separation for waterline parallel to sewer line (or 18" vertical separation in separate ditches).
  - d. For waterline, 18" clearance with storm drains.
  - e. For waterline, 12" clearance with gas mains, telephone ducts and underground cables.
  - f. For sanitary sewer, 18" clearance with storm drains.
  - g. Regardless of pipe material, a minimum 12" separation shall be required for water and sewer between other piping.
20. Initial connection to the existing water main shall be in accordance with the City of Kannapolis detail for a temporary bypass connection for filling new water mains. The temporary jumper connection shall be removed, and the waterline connected to the existing system only after satisfactory leakage and disinfection test results are provided to and accepted by the City of Kannapolis. No other connections will be allowed to the system until the proposed system has been accepted.
21. The contractor must notify the City a minimum of two business days in advance of any work to be performed on the weekends or on City Holidays. No work requiring testing or observation by the City shall be permitted without permission from the City Inspector.
22. The City's Noise Ordinance prohibits work outside of the following hours: 7:00am to 9:00pm – weekdays, 8:00am to 9:00pm weekends. Contractor must notify the City a minimum of two business days in advance of work to be performed outside of these hours. No work outside of these hours shall be performed without permission from the City Inspector.

### C. AS-BUILT RECORD DRAWING SUBMITTAL REQUIREMENTS

Prior to final acceptance of the improvements, the project engineer shall submit As-built record drawings of the site into Accela, containing:

- A signed and sealed copy of the as-built record drawings (PDF Format)
- An AutoCad (.dwg) file, and
- An ArcGIS (.shp) file

All deviations from the approved plans shall be reflected in both plan and profile sheets and clearly shown with red ink to distinguish from the design plans.

As-Built Record Drawings shall be tied to NAD 83 horizontal datum and to the NAVD 88 vertical datum. The project engineer shall provide all certifications that are required by the state for water and sewer improvements and that are required by the City for stormwater, water quality, and embankments.

As-Built Record Drawings shall include the following:

1. **Signature and Seal of NC Licensed Professional Engineer:** see 21 NCAC 56 .1103 (c) (7) for required statement by a licensed engineer sealing the As-Built record drawings if the original design engineer is unable to seal the As-Built Record Drawings.
2. **Site Impervious Area:** verify and label the total impervious area of the site.
3. **Sanitary Sewer**
  - a. Elevations: rim, invert in (including inside drop), and invert out.
  - b. Manhole size, material, and total vertical depth.
  - c. Summary table on cover sheet showing linear footage, material, diameter and slope of pipe installed.
  - d. Changes need to be reflected in both plan and profile sheets.
  - e. Permanent easements shown and clearly labeled as public or private, including map book and page of recorded easement (if applicable).
  - f. Lateral cleanouts shown in plan view.
  - g. Profile & cross section of all sewer easement outfalls.
  - h. Vertical Separation between sewer and all other utilities.
  - i. Certification by Engineer that sewer system was constructed in accordance with permit, if applicable. (Form available on NCDEQ Website)
4. **Water**
  - a. Valve, fitting, meter, and fire hydrant and backflow locations.
  - b. Summary table on cover sheet showing linear footage, material and diameter of pipe installed.
  - c. Verify minimum cover over pipe in profile view.
  - d. Show restrained joint pipe (if applicable).
  - e. Show distances between appurtenances in plan view.
  - f. Vertical separation between water and all other utilities.
  - g. Certification by Engineer that water system was constructed in accordance with permit, if applicable. (Form available on NCDEQ website.)
5. **Storm Drainage Conveyance Systems**
  - a. Invert elevations (invert in and out).
  - b. Rim elevations (junction boxes, gutter lines).
  - c. Invert elevations on culverts (box and pipe).
  - d. Flared end sections elevation.
  - e. Rip rap energy dissipation apron dimensions
  - f. Linear footage of piping, with slope, material and diameter of pipe installed clearly labeled.
  - g. Topographic survey of ditches.
  - h. Profile and cross section of all storm drainage easement outfalls.
  - i. All dimensions shall be shown in plan and profile views.
  - j. Vertical separation between Storm and all other utilities.
  - k. Updated pipe schedule.
  - l. Revised calculations of as-built storm drainage conveyance systems with a statement from the Engineer of either in compliance or not in compliance with the approved design.
  - m. Sealed Storm Drainage Conveyance System Certification. (Form Available in LDSM Appendix A)
6. **Stormwater Control Measures (SCM's)**
  - a. Method used to seal joints in pipes and wall openings.
  - b. Type and thickness of sand (sand filters).
  - c. Biomix material composition, thickness, and infiltration rate (Bioretention).
  - d. Channel liner materials.
  - e. Riser dimensions and elevations.
  - f. Anti-floatation block dimensions.
  - g. Stage storage chart for storage basins, forebays, detention areas, chambers, etc.
  - h. Revised calculations of as-built SCM conditions, sealed by the engineer confirming design complies with design guidelines for each SCM and that the system provides the required detention storage and reduced runoff discharge rates.

- i. As-built topo verifying:
  - i. Location and storage capacity of SCM.
  - ii. Basin side slopes (interior and exterior), top of embankment widths.
  - iii. Riser/spillway elevations and widths.
  - iv. Location of drainage features.
  - v. Location/outline of underground filter systems.
  - vi. Pipe inverts, pipe size, and pipe materials.
  - vii. Underdrain inverts, cleanout inverts, underdrain pipe size and materials.
  - viii. Thickness of energy dissipation aprons and filters.
  - ix. Orifice/weir inverts and dimensions.
  - x. Bottom drain gate size/type and critical elevations (invert and top of valve stem).
- j. Planted material certifications.
- k. Sealed SCM certification. (Form Available in LDSM Appendix A)
- l. Minimum of three pictures, which should include the outlet structure and full shots of the pond from opposite directions. Additional pictures should be provided if required to capture the full pond.

#### 7. Streets

(The below information should be provided in the .dwg and .shp file only.)

- a. Road profile
- b. Radius points
- c. Curb elevations
- d. Centerline alignment
- e. Sidewalk alignment
- f. Location of crosswalks and ADA ramps

## D. CERTIFICATIONS

In addition to water, sewer, stormwater conveyance system, and stormwater control measure certification as outlined in the sections above, certifications are also required for publicly maintained retaining walls, privately maintained retaining walls that encroach into public easements or right of way, bridges, and embankments. Certification forms for these items can be found in Appendix A.

## E. ENCROACHMENTS

1. Encroachments of any utilities, structures, or landscaping, including, but not limited to, driveways, pools, fences, trees, wells, reservoirs, or other obstructions, which would interfere with free, easy, and clear access to utilities on any easement, are prohibited. However, certain utilities, structures, filling, or grading may be permitted upon approval of a Utility Encroachment Application or an express Encroachment Agreement. The City of Kannapolis may require additional information depending on the type of encroachment.
2. To apply for a utility encroachment within a City easement or right of way, complete the **Utility Encroachment Application** found in Appendix A. The form should be completed in full and submitted to the engineering department for review.
3. To apply for all other encroachments within City easement or right of way, contact the Director of Engineering. The following information shall be provided when requesting an encroachment:
  - a. A description of the proposed encroachment(s)
  - b. A map of the proposed encroachment(s) with:
    - i. Site plan/map showing location of easements or right of way with the proposed encroachment(s) clearly shown and labeled
    - ii. Reference to the plat or deed book and page number that contains the property and/or easement.
4. The Director of Engineering may impose additional and reasonable conditions upon the granting of any encroachment.
5. The party responsible for any unpermitted or unauthorized encroachment shall, at their own expense, remove the encroachment immediately upon written notice from the City.

## CHAPTER 7 REFERENCES

1. American Association of State Highway and Transportation Officials most recent edition, A Policy on Geometric Design of Highways and Streets
2. Charlotte-Mecklenburg SCM Design Manual
3. Charlotte-Mecklenburg Wastewater Pump Stations
4. City of Charlotte Storm Water Services-Mecklenburg County Storm Water Services, Charlotte-Mecklenburg Storm Water Design Manual
5. City of Charlotte – Charlotte Water’s Design Manual
6. Contech – CMP Design Guide
7. Federal Highway Administration, Manual on Uniform Traffic Control Devices (MUTCD)
8. International Fire Code
9. Massachusetts Highways – Shared Use Paths and Greenways
10. Mecklenburg County Greenways – General Planning and Design Guidelines
11. National Association of City Transportation Officials, Urban Bikeway Design Guide
12. National Bridge Inspection Standards – Code of Federal Regulations
13. North Carolina Building Code
14. North Carolina Department of Environmental Quality, Minimum Design Criteria for the Permitting of Pump Stations and Force Mains
15. North Carolina Department of Environmental Quality, Stormwater Control Measures
16. North Carolina Department of Environment and Natural Resources, Erosion and Sediment Control Planning and Design Manual
17. North Carolina Department of Transportation, Asphalt Quality Management System Manual
18. North Carolina Department of Transportation, Complete Streets Planning and Design Guidelines
19. North Carolina Department of Transportation, Greenway Design Guidelines
20. North Carolina Department of Transportation, Policy on Street and Driveway Access
21. North Carolina Department of Transportation, Roadway Design Manual
22. North Carolina Department of Transportation, Roadway Standards Drawings
23. North Carolina Department of Transportation, Standard Specifications for Roads and Structures
24. Roundabouts: An Informational Guide (FHWA Publication No. RD-00-067)
25. Water and Sewer Authority of Cabarrus County (WSACC)

## Chapter 8 STANDARD DRAWINGS

### A. INDEX

#### **100 SERIES - STREETS & DRAINAGE**

- 101A TYPICAL SECTION – LOCAL RESIDENTIAL STREET
- 101B TYPICAL SECTION – LOCAL RESIDENTIAL STREET DITCH TYPE SECTION (WITH SIDEWALK)
- 101C TYPICAL SECTION – LOCAL RESIDENTIAL STREET DITCH TYPE SECTION (NO SIDEWALK)
- 102 TYPICAL SECTION – RESIDENTIAL COLLECTOR STREET
- 103 TYPICAL SECTION – NON-RESIDENTIAL STREETS
- 104A TYPICAL SECTION – CUL-DE-SAC
- 104B TYPICAL SECTION – RESIDENTIAL HAMMERHEAD
- 105A TYPICAL SECTION – ROAD WIDENING
- 105B TYPICAL SECTION – ROAD WIDENING FULL DEPTH OVERLAY
- 106 TYPICAL SECTION – RESIDENTIAL ALLEY
- 107 TYPICAL SECTION – GRAVEL ROAD ACCESS
- 108 TYPICAL DRIVEWAY & INTERSECTION LAYOUT
- 109 UTILITY CUT PAVEMENT REPAIR DETAIL
- 110 INTERSECTION SIGHT TRIANGLES
- 111 DRIVEWAY ENTRANCE – RADIUS
- 112 DRIVEWAY ENTRANCE – DROP CURB
- 113A DRIVEWAY ENTRANCE – 2'-0" VALLEY GUTTER
- 113B DRIVEWAY ENTRANCE – WITH NO CURB (EXISTING CONDITIONS)
- 114 DRIVEWAY ENTRANCE – TYPE III DRIVEWAY
- 115 CURB AND GUTTER
- 116 CURB TRANSITIONS
- 117 CONCRETE SIDEWALKS
- 118 TRUNCATED DOME DETAILS
- 119 PERPENDICULAR CURB RAMP WITH 2'-6" CURB & GUTTER
- 120 PERPENDICULAR CURB RAMP WITH 2'-0" VALLEY GUTTER
- 121 DIRECTIONAL CURB RAMP WITH SMALL/MEDIUM CURB RADII
- 122 DIRECTIONAL CURB RAMP WITH LARGE CURB RADIUS
- 123 CROSSWALK STRIPING DETAIL
- 124 END OF ROADWAY BARRICADE
- 125 END OF ROADWAY MARKER
- 126A CATCH BASIN FRAME IN VALLEY GUTTER
- 126B VALLEY GUTTER FRAME AND GRATE
- 127 RESIDENTIAL DRIVEWAY PIPE DETAIL FOR DITCH SECTION STREET
- 128A FLARED END SECTION

- 128B RIP RAP APRON AT PIPE OUTFALLS
- 129 BRICK DOUBLE CATCH BASIN 15" - 36" PIPE
- 130 OFFSET CATCH BASIN
- 131 GRADING AT DROP INLET
- 132A CULVERT CROSSING ON RESIDENTIAL & COMMERCIAL STREETS
- 132B CULVERT CROSSING ON RESIDENTIAL & COMMERCIAL STREETS
- 133 MEDIAN DIVIDED STREET ENTRANCE

### **200 SERIES - EROSION CONTROL**

- 201 TEMPORARY DRAINAGE AT CATCH BASINS
- 202 TEMPORARY CONSTRUCTION ENTRANCE
- 203 SILT FENCE DETAIL
- 204 SILT FENCE OUTLET DETAIL
- 205 SILT BAG INLET PROTECTION
- 206 THROATED INLET PROTECTION
- 207 HARDWARE CLOTH AND GRAVEL INLET PROTECTION
- 208 TEMPORARY SILT DITCH
- 209 TEMPORARY ROCK CHECK DAM
- 210 TEMPORARY WATTLE CHECK DAM WITH MATTING
- 211 FLARED END SECTION INLET PROTECTION
- 212 CONCRETE WASHOUT PIT

### **300 SERIES - UTILITIES**

- 301 TYPICAL SECTION UTILITY LAYOUT
- 302 OVERLAPPING EASEMENTS SANITARY SEWER-STORM DRAINAGE
- 303 RELATION OF WATER & SEWER MAINS TO STORM DRAINS
- 304 RELATION OF WATER & SEWER MAINS
- 305 CASING SPIDER
- 306 ENCASEMENT PIPES UNDER HIGHWAYS & RAILROADS
- 307 ENCASEMENT PIPES UNDER STREAM CROSSINGS
- 308 ANTI-SEEP COLLAR FOR SEWER/WATER LINES
- 309 EMBEDMENTS FOR MAINS
- 310 DOMESTIC WATER SERVICE DETAIL – ¾" WATER METER CONNECTION W/ 1" TEE FOR IRRIGATION CONNECTION
- 311 WATER SERVICE PLAN – WATER METER CONNECTION W/ TEE FOR IRRIGATION CONNECTION
- 312 WATER SERVICE DETAIL– ¾" WATER METER CONNECTION
- 313 WATER SERVICE – 1" WATER METER CONNECTION W/ 1" TEE FOR CONNECTION
- 314 WATER SERVICE DETAIL – 1" WATER METER CONNECTION

- 315 WATER SERVICE – 1 ½"-2" WATER METER CONNECTION
- 316 WATER SERVICE – 3", 4" & 6" COMPOUND WATER METER AND VAULT
- 317 BACKFLOW PREVENTION – ¾"-2" REDUCED PRESSURE PRINCIPLE ASSEMBLY (RP)
- 318 BACKFLOW PREVENTION – 3"-10" REDUCED PRESSURE DETECTOR ASSEMBLY (RPDA)
- 319 BACKFLOW PREVENTION – ¾"-2" DOUBLE CHECK VALVE ASSEMBLY (DCVA)
- 320 BACKFLOW PREVENTION – 3"-10" DOUBLE CHECK DETECTOR ASSEMBLY (DCDA)
- 321 FIRE HYDRANT
- 322 6" FIRE HYDRANT WITH 2 STORZ CONNECTIONS
- 323 WATER SERVICE – TYPICAL FIRE LINE CONNECTION
- 324 REDUCED PRESSURE PRINCIPLE BACKFLOW PREVENTION ASSEMBLY FOR HYDRANT METERS
- 325 JUMPER – BY-PASS CONNECTION FOR FILLING NEW WATER MAINS
- 326 MINIMUM PROTECTION FOR FILLING TANKER TRUCK
- 327 THRUST BLOCK – TEES
- 328 THRUST BLOCK – BENDS
- 329 STANDARD VERTICAL BEND ANCHORS
- 330 DEAD END BLOW-OFF WITH THRUST COLLAR
- 331 TEMPORARY BLOW-OFF ASSEMBLY
- 332 VALVE BOX ADJUSTMENT DETAIL
- 333 STANDARD PRECAST CONCRETE MANHOLE
- 334 DOGHOUSE MANHOLE
- 335 STANDARD DROP-MANHOLE
- 336 STANDARD EXTERIOR-DROP CONNECTION FOR SANITARY SEWER MANHOLE
- 337 STANDARD AIR RELIEF VALVE WITH ASSEMBLY AND MANHOLE FOR WATER OR SEWER LINES
- 338 STANDARD VENT FOR PRECAST CONCRETE MANHOLE
- 339 SEWER TRACER WIRE
- 340 MANHOLE FORCEMAIN CONNECTION
- 341 MANHOLE ADJUSTMENT DETAIL
- 342 PIPE ADAPTER DIP TO PVC
- 343A WASTEWATER SERVICE LATERAL CONNECTION
- 343B WASTEWATER SERVICE LATERAL CONNECTION IN PAVED AREAS
- 343C WASTEWATER SERVICE 6-INCH LATERAL CONNECTION
- 344 5" STORZ CONNECTION DETAIL
- 345A WATER QUALITY SAMPLING STATION (1 OF 2)
- 345B WATER QUALITY SAMPLING STATION (2 OF 2)
- 346 ODOR CONTROL FOR SEWER PUMPING
- 347 TEMPORARY FAUCET
- 348 TAPPING SLEEVE AND VALVE

- 349 BACK SIDE TAP 16" AND SMALLER
- 350A STANDARD GRAVITY GREASE INTERCEPTOR
- 350B STANDARD GRAVITY GREASE INTERCEPTOR IN SERIES

#### **400 SERIES - MISCELLANEOUS**

- 401 TYPICAL SECTION – GREENWAY TRAIL – ASPHALT
- 402 TYPICAL SECTION – GREENWAY TRAIL – CONCRETE
- 403 BOLLARD
- 404 COLLAPSIBLE BOLLARD DETAIL
- 405 TYPICAL BOLLARD PLACEMENT
- 406 SAFETY RAIL
- 407 SAFETY RAIL WARRANTS
- 408 PARKING STANDARDS
- 409 ACCESSIBLE PARKING & SIGNAGE STANDARDS
- 410 SUPPLEMENTAL VAN ACCESSIBLE SIGN (R7-8P)
- 411 SINGLE DUMPSTER PAD
- 412 DOUBLE DUMPSTER PAD
- 413 DUMPSTER PAD – SECTION WITH CURB
- 414 DUMPSTER ENCLOSURE
- 415 TYPICAL CK RIDER BUS STOP DETAIL
- 416 STUB STREET SIGN DETAIL

## **B. DRAWINGS**

The Kannapolis Standard Drawings shown are to be used for design and construction of projects within the City of Kannapolis. For construction activities not shown by Kannapolis Standard Drawings, NCDOT Standard Drawings shall be used.



## APPENDIX A

### Index of Tables, Diagrams, Certifications, and Permits:

<b><u>Tables</u></b>	<b><u>Page No:</u></b>
A1 STANDARDS OF STREET DESIGN	A-2
A2 STOPPING SIGHT DISTANCE	A-3
A3 DESIGN INTERSECTION SIGHT DISTANCE, LEFT TURN FROM STOP	A-3
A4 GREENWAY MINIMUM STOPPING SIGHT DISTANCE	A-4
A5 SANITARY SEWER PIPE SIZING & MATERIAL	A-4
A6 WATER DISTRIBUTION PIPE SIZING & MATERIAL	A-4
A7 MANDREL DIMENSIONS	A-5
A8 MAXIMUM COVER FOR POLYPROPYLENE PIPE	A-5
A9 CASING PIPE SIZES	A-5
A10 AIR TEST TABLE	A-6
A11 PUBLIC UTILITY EASEMENT WIDTH CHART	A-7
<b><u>Diagrams</u></b>	
A1 DEAD-END FIRE APPARATUS ACCESS ROAD TURNAROUND	A-8
A2 INTERSECTION GRADES	A-9
A3 RETAINING WALLS	A-10
<b><u>Certifications</u></b>	
STORM DRAINAGE AS-BUILTS	A-11
STORMWATER CONTROL MEASURE S(SCM)	A-12
RETAINING WALLS	A-13
BRIDGES	A-14
EMBANKMENTS	A-15
<b><u>Permits</u></b>	
CITY EROSION CONTROL PERMIT (for projects < 1.0 ac)	A-16
RESIDENTIAL DRIVEWAY PERMIT	A-18
UTILITY ENCROACHMENT PERMIT APPLICATION	A-19

TABLE A1 – STANDARDS OF STREET DESIGN

Street Type	Alley	Local	Collector	Thoroughfare
<b>Average Daily Traffic (ADT)</b>	100	250	3000 Major 1000 Minor	8000 Major 4000 Minor
<b>Longitudinal Grade</b> Min  Max: level/rolling hilly (stop/yield) at intersection (thru movement) at intersection Within 100' of an intersection	1%	1%	1%	See Thoroughfare Plan
	10 %	10 %	8 %	
	10 %	10 %	10 %	
	5 %	2 %	2 %	
	5 %	5 %	5 %	
<b>Min Horizontal Centerline Curve Radius</b>		150'	230'	
<b>Min Tangent between Reverse Curves</b>		50'	100'	
<b>Street Intersection Radius<sup>(6)</sup></b>	20'	30'	30'	
<b>Design Speed</b> Min  Max	15 mph	25 mph	25 mph	
	15 mph	35 mph	35 mph	
<b>Design Vehicle</b>  Residential Non-Residential	<b>Alley</b>	<b>Local</b>	<b>Collector</b>	<b>Thoroughfare</b>
	SU-30	SU-30	Bus-45 & SU-30	WB-62
	SU-30	SU-30	WB-62 or WB-40	WB-62
<b>Separation<sup>(1)(2)(3)</sup></b> driveway - driveway  driveway - intersection driveway - residential prop. line driveway - non-residential prop. line intersection - intersection	40'	40'	120'	400'
	25'	60'	120'	250'
	5'	5'	5'	5'
	10'	10'	10'	10'
	N/A	200'	200'	600'-1000'
<b>Pavement Schedule<sup>(4)(5)</sup></b>  surface course (S9.5C) intermediate course (I19.0C) base course (residential) base course (non-residential)	<b>Alley</b>	<b>Local</b>	<b>Collector</b>	<b>Thoroughfare</b>
	2"	2-1" Lifts	2-1" Lifts	See NCDOT Roadway Design Standards
	0"	2.5"	2.5"	
	8" ABC or 4" B25.0C			
N/A 10" ABC or 5" B25.0C				
<b>Max Cul-de-sac Lengths</b>  Zoning	R4, R8	AG, R1, R2	CD, LI, HI	MU, O-I, C-1, GC, PD
	800'	1000'	1500'	500'
	R18, CC			
	300'			
<b>Dead-End Fire Apparatus Access Roads</b>  Length Width Vertical clearance Maximum grade  Turnaround required	0-150'	150'-500'	500'-750'	750'+
	20'	20'	26'	Special Approval Required
	13.5'	13.5'	13.5'	
	10 %	10 %	10 %	
	60' "Y"			
None	96' ø Cul-De-Sac 120' Hammerhead (Temporary)			

- Notes:
1. Single-family dwellings and duplex dwellings on individual lots shall be exempt from the minimum separation between driveways as shown in the table above. However, such driveways shall maintain a minimum of 5' of side clearance from residential property lines and 10' for all others.
  2. City streets: proposed streets which intersect opposite sides of another street (either existing or proposed) shall be laid out to intersect directly opposite each other. Intersections which cannot be aligned shall be separated by a minimum length of 200' between survey centerlines.
  3. For state-maintained streets, reference the NCDOT Policy on Street and Driveway Access to North Carolina Highways.
  4. Non-residential street pavement design shall be evaluated on a case-by-case basis.
  5. Prior to substituting B25.0C, approval shall be obtained from the Director of Engineering.
  6. Radius measured from edge of pavement.

TABLE A2 – STOPPING SIGHT DISTANCE

MINIMUM STOPPING SIGHT DISTANCE (ft)							
Vehicle Speed (mph)	UPGRADES			FLAT	DOWNGRADES		
	9 %	6 %	3 %	0 %	-3 %	-6 %	-9 %
25	140	145	150	155	160	165	175
30	180	185	200	200	205	215	230
35	225	230	240	250	260	275	290
40	270	280	290	305	315	335	355
45	320	330	345	360	380	400	430
50	375	390	405	425	450	475	510

TABLE A3 – DESIGN INTERSECTION SIGHT DISTANCE, LEFT TURN FROM STOP

Design Speed (mph)	Stopping Sight Distance (ft)	Intersection Sight Distance for Passenger Cars	
		Calculated (ft)	Design (ft)
15	80	165.4	170
20	110	220.5	225
25	155	275.6	280
30	200	330.8	335
35	250	385.9	390
40	305	441.0	445
45	360	496.1	500
50	425	551.3	555

**TABLE A4 – GREENWAY MINIMUM STOPPING SIGHT DISTANCE**

A	English Units - Minimum Length of Crest Vertical Curve (L) Based on Stopping Sight Distance														
	20	40	60	80	100	120	140	160	180	200	220	240	260	280	300
2												30	70	110	150
3								20	60	110	140	180	220	260	300
4						15	55	95	135	175	215	256	300	348	400
5					20	60	100	140	180	222	269	320	376	436	500
6				10	50	90	130	171	216	267	323	384	451	523	600
7				31	71	111	152	199	252	311	376	448	526	610	700
8			8	48	88	128	174	228	288	356	430	512	601	697	800
9			20	60	100	144	196	256	324	400	484	576	676	784	900
10			30	70	111	160	218	284	360	444	539	640	751	871	1000
11			38	78	122	176	240	313	396	489	592	704	826	958	1100
12		5	45	85	133	192	261	341	432	533	645	768	901	1045	1200

1. When  $S > L = 2S - 900/A$       Shaded area represents  $S = L$
2. When  $S < L = AS^2/900$   
 L = Minimum Length of Vertical Curve (ft)  
 A = Algebraic Grade Difference (%)  
 S = Stopping Sight Distance (ft)  
 Height of Cyclist's Eye = 4.5'  
 Height of Object = 0'  
 Minimum Length of Vertical Curve = 3'

Source: AASHTO, Guide for the Development of Bicycle Facilities

**TABLE A5 – SANITARY SEWER PIPE SIZING & MATERIAL**

Material	Pipe Diameter (in)
Solid wall ASTM D3034, SDR 35, Cell Classification 12454	4 - 15
Profile wall ASTM F794 Stiffness PS46	18 - 48
Ductile Iron Pipe (DIP) Class 50	All Sizes

**TABLE A6 – WATER DISTRIBUTION PIPE SIZING & MATERIAL**

Material	Pipe Diameter (in)
PVC SDR 13.5	2 - 4
PVC C900	6 - 12
Ductile Iron Pipe (DIP) Class 350	3 - 12
Ductile Iron Pipe (DIP) Class 250	16 +

TABLE A7 – MANDREL DIMENSIONS

Pipe Type	Pipe Diameter	Minimum Inside Diameter	Inside Diameter with 5% Deflection
Dual Wall	15"	14.85	14.11
	18"	17.93	17.03
	24"	23.90	22.71
	30"	29.89	28.30
Triple Wall	30"	29.62	28.14
	36"	35.40	33.63
	42"	41.31	39.24
	48"	47.31	44.94
	60"	59.30	56.34

TABLE A8 – MAXIMUM COVER FOR POLYPROPYLENE PIPE

Diameter	Class 1	Class 2			Class 3		Class 4
	Compacted	95%	90%	85%	95%	90%	95%
12"	39	27	20	9	21	12	11
15"	42	29	21	10	22	12	11
18"	36	25	18	9	19	12	11
24"	31	22	16	7	16	11	10
30"	33	23	17	9	17	11	10
36"	32	22	16	7	16	11	10
42"	32	22	15	7	16	11	10
48"	31	21	15	6	15	10	9
60"	34	23	16	6	16	11	10

TABLE A9 CASING PIPE SIZES

Pipe Diameter	HIGHWAY		RAILROAD	
	Casing O.D.	Min. Wall Thickness	Casing O.D.	Min. Wall Thickness
6"	12.75"	0.188"	12.75"	0.250"
8"	18"	0.250"	18"	0.312"
12"	24"	0.250"	24"	0.406"
16"	30"	0.312"	30"	0.500"
24"	36"	0.375"	36"	0.5625"

**TABLE A10 – AIR TEST TABLE**

<b>Length of Line (ft)</b>	<b>4</b>	<b>6</b>	<b>8</b>	<b>10</b>	<b>12</b>	<b>15</b>	<b>18</b>	<b>21</b>	<b>24</b>
<b>25</b>	0:04	0:10	0:18	0:28	0:40	1:02	1:29	2:01	2:38
<b>50</b>	0:09	0:20	0:35	0:55	1:19	2:04	2:58	4:03	5:17
<b>75</b>	0:13	0:30	0:53	1:23	1:59	3:06	4:27	6:04	7:55
<b>100</b>	0:18	0:40	1:10	1:50	2:38	4:08	5:56	8:05	10:34
<b>125</b>	0:22	0:50	1:28	2:18	3:18	5:09	7:26	9:55	11:20
<b>150</b>	0:26	0:59	1:46	2:45	3:58	6:11	8:30	9:55	11:20
<b>175</b>	0:31	1:09	2:03	3:13	4:37	7:05	8:30	9:55	11:20
<b>200</b>	0:35	1:19	2:21	3:40	5:17	7:05	8:30	9:55	11:20
<b>225</b>	0:40	1:29	2:38	4:08	5:40	7:05	8:30	10:25	13:36
<b>250</b>	0:44	1:39	2:56	4:35	5:40	7:05	8:31	11:35	15:07
<b>275</b>	0:48	1:49	3:14	4:43	5:40	7:05	9:21	12:44	16:38
<b>300</b>	0:53	1:59	3:31	4:43	5:40	7:05	10:12	13:53	18:09
<b>350</b>	1:02	2:19	3:47	4:43	5:40	8:16	11:54	16:12	21:10
<b>400</b>	1:10	2:38	3:47	4:43	6:03	9:27	13:36	18:31	24:12
<b>450</b>	1:19	2:50	3:47	4:43	6:48	10:38	15:19	20:50	27:13
<b>500</b>	1:28	2:50	3:47	5:15	7:34	11:49	17:01	23:09	30:14

Note: If the length of sewer to be tested is submerged or partially submerged in groundwater, the test pressure shall be increased as required to overcome the actual static pressure exerted by the groundwater. If a test pressure greater than 8 psi results, air testing shall not be used and exfiltration testing will be required.

TABLE A11 – UTILITY EASEMENT WIDTH CHART

SEWER MAIN PIPE								
Diameter (in)	Diameter (ft)	Min. Bottom Width (ft)	Max. depth to bottom of pipe @ Esmt Width (ft)					
			20'	25'	30'	35'	40'	45'
8	0.67	2.67	8.67	11.17	13.67	16.17	18.67	21.17
12	1.00	3.00	8.50	11.00	13.50	16.00	18.50	21.00
16	1.33	3.33	8.33	10.83	13.33	15.83	18.33	20.83
24	2.00	4.00	8.00	10.50	13.00	15.50	18.00	20.50

\* - Depth beyond those shown on this chart shall require additional easement width to the nearest 5' increment.

STORM PIPE									
Pipe Inner Diameter (in)	Wall Thickness (in)	Pipe Outer Diameter (ft)	Min. Bottom Width (ft)	Max. depth to bottom of pipe @ Esmt Width (ft.)					
				20'	25'	30'	35'	40'	50'
15	2.25	1.63	3.63	8.19	10.69	13.19	15.69	18.19	20.91
18	2.50	1.92	3.92	8.04	10.54	13.04	15.54	18.04	20.98
24	3.00	2.50	4.50	7.75	10.25	12.75	15.25	17.75	21.13
30	3.50	3.08	5.08	7.46	9.96	12.46	14.96	17.46	21.27
36	4.00	3.67	5.67	7.17	9.67	12.17	14.67	17.17	21.42
42	4.50	4.25	6.25	6.88	9.38	11.88	14.38	16.88	21.56
48	5.00	4.83	6.83	6.58	9.08	11.58	14.08	16.58	21.71
54	6.25	5.54	7.54	6.23	8.73	11.23	13.73	16.23	21.89
60	6.75	6.13	8.13	5.94	8.44	10.94	13.44	15.94	22.03
66	7.25	6.71	8.71	5.65	8.15	10.65	13.15	15.65	22.18
72	7.00	7.17	9.17	5.42	7.92	10.42	12.92	15.42	22.29

\* - Depth beyond those shown on this chart shall require additional easement width to the nearest 5' increment.

# DIAGRAM A1 – DEAD-END FIRE APPARATUS ACCESS ROAD TURNAROUND

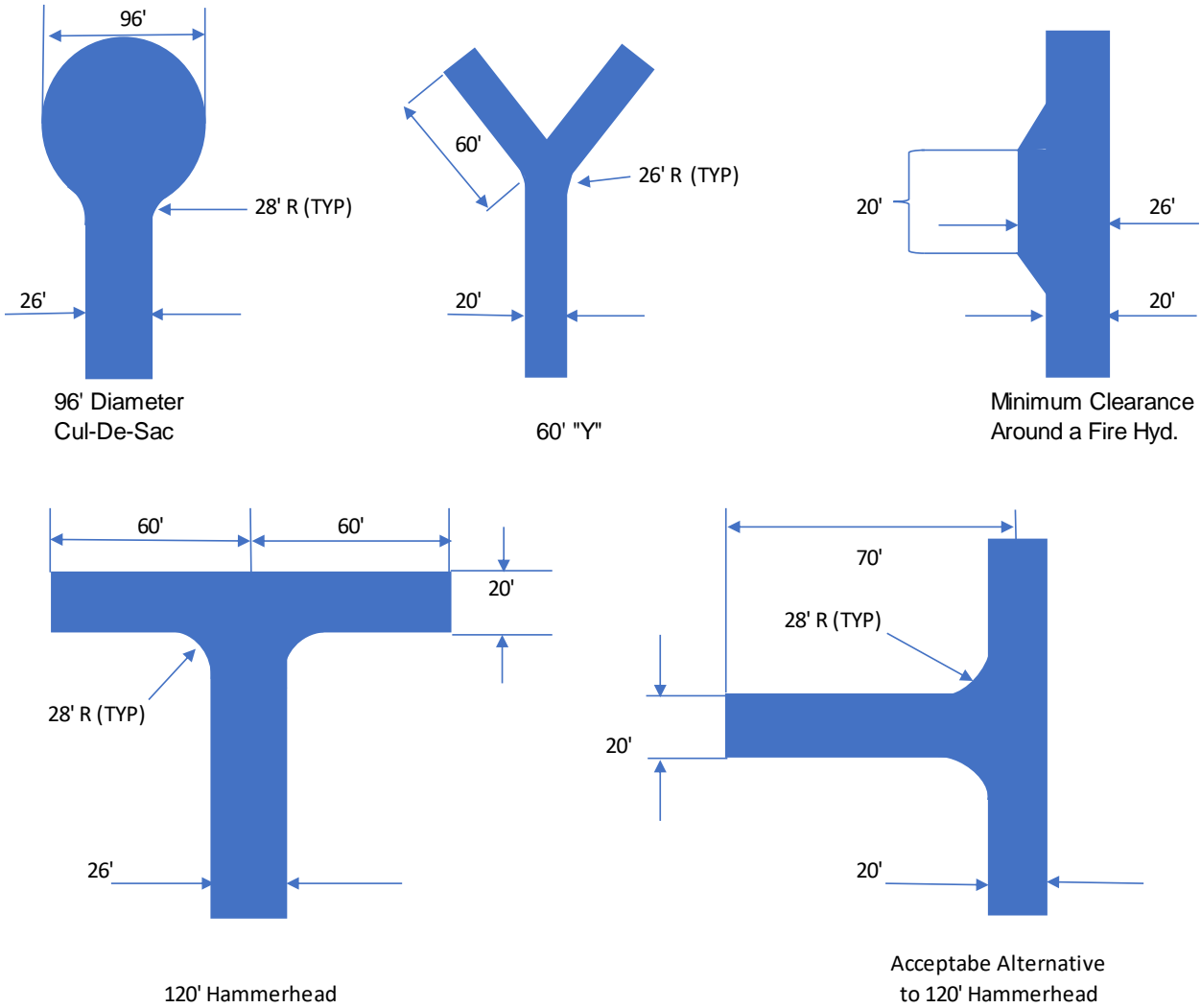

**Notes:**

1. Turnarounds to be contained within R/W.
2. Acceptable pavement schedule alternative is 6" ABC, Geotextile, 12" min compacted subgrade to be approved by the Director of Engineering.



DIAGRAM A2 – INTERSECTION GRADES

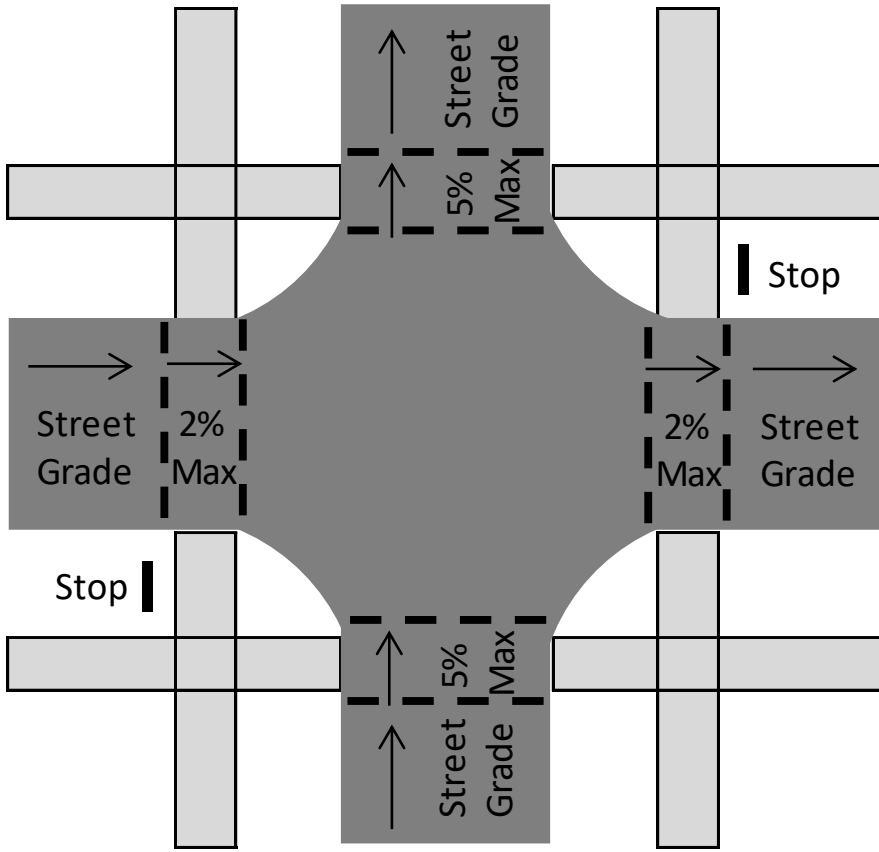

# DIAGRAM A3 – RETAINING WALLS

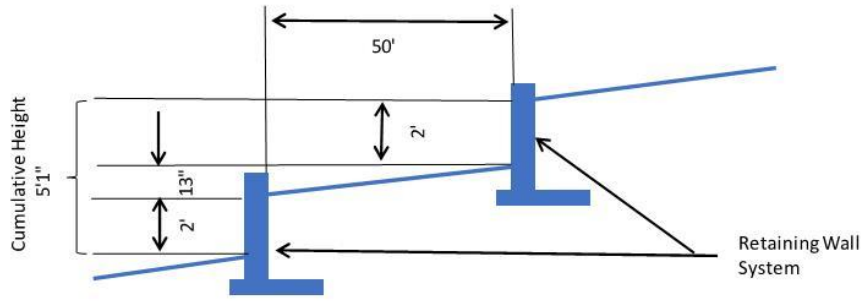

Example - A  
Design Professional Required

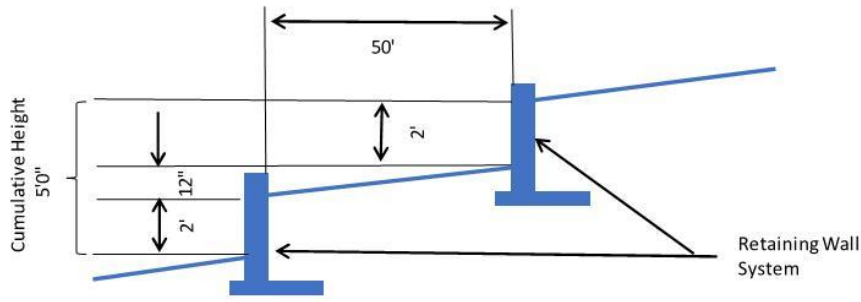

Example - B  
Design Professional Not Required

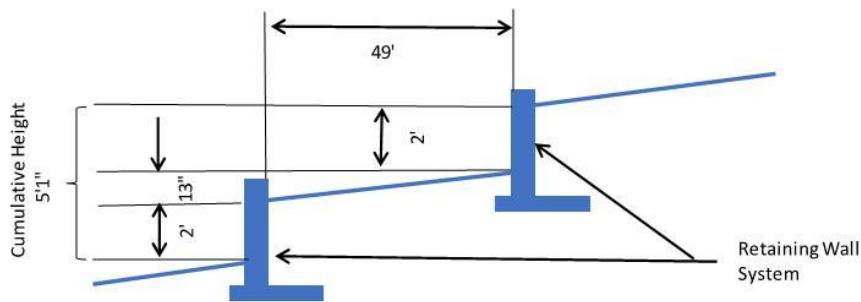

Example - C  
Design Professional Required

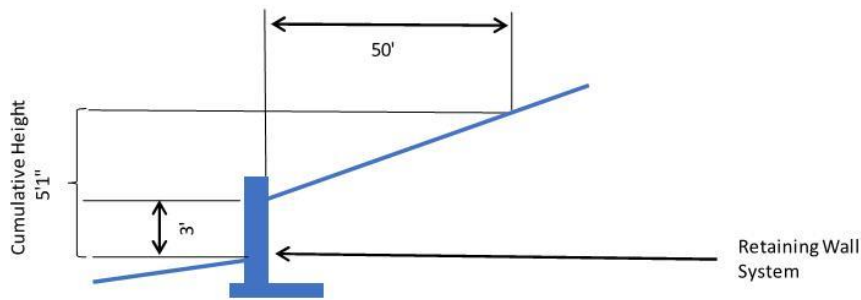

Example - D  
Design Professional Required

## STORM DRAINAGE CONVEYANCE SYSTEM CERTIFICATION

## As-Built Certification

I, \_\_\_\_\_, attest that this certification, for the \_\_\_\_\_ Project, has been reviewed by me and is accurate, complete and consistent with the information supplied in the plans, specifications, engineering calculations, and all other supporting documentation to the best of my knowledge. I further attest that to the best of my knowledge the Storm Drainage As-Built Plans have been prepared based on an accurate account of the stormwater piping and appurtenances installed during construction and any deviations from the approved construction plans shall not adversely impact the drainage system, discharge points, and/or adjacent properties analyzed during the approval process of the construction plans. Although other professionals may have developed certain portions of this submittal package, inclusion of these materials under my signature and seal signifies that I have reviewed this material and have judged it to be consistent with the proposed design.

SEAL:

\_\_\_\_\_  
(Date)

\_\_\_\_\_  
(Signature)

Engineer:  
Firm:  
Firm License #:  
Address:

## STORMWATER CONTROL MEASURE (SCM) CERTIFICATION

Licensed Professional Engineer to provide certification statement for each SCM

### **As-Built Certification**

**Project:**

**SCM # and Type:**

I, \_\_\_\_\_, attest that this certification, has been reviewed by me and is accurate, complete and consistent with the information supplied in the plans specifications, engineering calculations, and all other supporting documentation to the best of my knowledge. I further attest that to the best of my knowledge the As-Built Plans have been prepared based on an accurate account of the SCM and appurtenances installed during construction and any deviations from the approved construction plans were analyzed and verified to not adversely impact the performance of the SCM during the approval process of the construction plans. Although other professionals may have developed certain portions of this submittal package, inclusion of these materials under my signature and seal signifies that I have reviewed this material, conducted a physical site visit, verified all applicable vegetative plantings have been installed, and have judged it to be consistent with the approved design.

SEAL:

\_\_\_\_\_  
(Date)

\_\_\_\_\_  
(Signature)

Engineer:

Firm:

Firm License #:

Address:

Provide sufficient photographs of each SCM design component as part of the certification.

# RETAINING WALL CERTIFICATION

## As-Built Certification

I, \_\_\_\_\_, attest that this certification, for the \_\_\_\_\_ Project, has been reviewed by me and is accurate, complete and consistent with the information supplied in the plans, specifications, engineering calculations, and all other supporting documentation to the best of my knowledge. I further attest that to the best of my knowledge the As-Built Plans have been prepared based on an accurate account of the retaining wall system and appurtenances installed during construction and any deviations from the approved construction plans were analyzed and verified to not adversely impact the performance of the wall system analyzed during the approval process of the construction plans. Although other professionals may have developed certain portions of this submittal package, inclusion of these materials under my signature and seal signifies that I have reviewed this material and have judged it to be consistent with the proposed design.

SEAL:

\_\_\_\_\_  
(Date)

\_\_\_\_\_  
(Signature)

Engineer:

Firm:

Firm License #:

Address:

## BRIDGE CERTIFICATION

### As-Built Certification

I, \_\_\_\_\_, attest that this certification, for the \_\_\_\_\_ Project, has been reviewed by me and is accurate, complete and consistent with the information supplied in the plans, specifications, engineering calculations, and all other supporting documentation to the best of my knowledge. I further attest that to the best of my knowledge the As-Built Plans have been prepared based on an accurate account of the bridge and appurtenances installed during construction and any deviations from the approved construction plans were analyzed and verified to not adversely impact the performance of the bridge analyzed during the approval process of the construction plans. Although other professionals may have developed certain portions of this submittal package, inclusion of these materials under my signature and seal signifies that I have reviewed this material and have judged it to be consistent with the proposed design.

SEAL:

\_\_\_\_\_  
(Date)

\_\_\_\_\_  
(Signature)

Engineer:

Firm:

Firm License #:

Address:

# CERTIFICATION OF EMBANKMENTS

## As-Built Certification

I, \_\_\_\_\_, attest that this certification, for the \_\_\_\_\_ Project, has been reviewed by me and is accurate, complete, and consistent with the information supplied in the plans, specifications, and all other supporting documentation to the best of my knowledge. I further attest that to the best of my knowledge the As-Built Plans have been prepared based on an accurate account of the embankment fill elevation, compaction, slope, and slope protection materials installed during construction and any deviations from the approved construction plans were analyzed and verified to not adversely impact the performance of the embankment during the approval process of the construction plans. Although other professionals may have developed certain portions of this submittal package, inclusion of these materials under my signature and seal signifies that I have reviewed this material and have judged it to be consistent with the proposed design.

SEAL:

\_\_\_\_\_  
(Date)

\_\_\_\_\_  
(Signature)

Engineer:

Firm:

Firm License #:

Address:

# EROSION CONTROL PERMIT APPLICATION

## **Applicant Contact Information**

Name: \_\_\_\_\_

Phone: \_\_\_\_\_

## **Project Information**

Type of Construction: (Residential/Commercial): \_\_\_\_\_

Address: \_\_\_\_\_

Parcel & Lot #: \_\_\_\_\_

Disturbed Area (ac): \_\_\_\_\_

Date of land disturbing activity: \_\_\_\_\_

## **Applicant agrees to the following items:**

1. Call One-Call before digging 811 or 1-800-351-1111 and allow 3 business days before digging.
2. Install and maintain in proper working order, erosion control measures as needed to prevent sedimentation from leaving the construction site.
3. Remove any sediment and or aggregate discharged onto streets immediately.

---

Applicant Signature

Date



## RESIDENTIAL INSPECTION REQUIREMENTS

There are five (5) inspections required by the City of Kannapolis Engineering Department. These inspections must be completed **before** the Certificate of Occupancy will be issued. Inspections are scheduled through your Citizen Access account and will be performed the next business day, from 8:00am to 5:00pm. No specific inspection time will be provided. There is a \$50.00 reinspection fee for each failed inspection:

1. Driveway Pipe Review:

- This inspection will be after the pipe is in place but not covered
- Verify the correct type of the pipe and installation

2. Driveway Review:

- This inspection should be requested after all forms for Driveway are in place.
- All soft areas in the subgrade have been repaired.
- Before any concrete is poured.
- Driveway should meet all LDSM requirements

3. Sidewalk Review

- This inspection should be requested after all forms for Sidewalk are in place.
- All soft areas in the subgrade have been repaired.
- Before any concrete is poured.
- Sidewalk should meet all LDSM requirements

4. Drainage Review

- This inspection should be requested after fine grading has been completed.
- Lot is graded in general conformity with the plans.
- Lot grading does not negatively impact adjacent properties.
- Existing infrastructure is not impacted by the development.

5. Water and Sewer Review

- This inspection should be requested after sod or seed/straw has been placed.
- Sewer lateral has cast iron cap with stainless steel band and be set to grade.
- Water meter box and irrigation box (if applicable) set to grade.
- No damage to the boxes or clean out.
- Boxes are clear of mud and debris.

# ENGINEERING INSPECTION PERMIT APPLICATION

## Applicant Contact Information

Name: \_\_\_\_\_

Phone: \_\_\_\_\_ Email: \_\_\_\_\_

## Project Information

Address: \_\_\_\_\_ PIN: \_\_\_\_\_

Contractor Name: \_\_\_\_\_

## Applicant agrees to the following items:

1. For driveway pipe, driveway, sidewalk, grading, and water/sewer inspections, the Citizen Access email account that will be used to schedule the inspections is:

Email: \_\_\_\_\_

This Citizen Access email account will be linked to the KN-INSP record and will be used by the applicant to schedule the inspections.

2. Construct and maintain driveway(s) in absolute conformance with the current "Policy on Street and Driveway Access" as adopted by the City of Kannapolis [Land Development Standards Manual](#)
3. Provide proper signs, traffic control and other warning devices for the protection of traffic in conformance with the current "Manual on Uniform Traffic Control Devices for Streets and Highways" MUTCD
4. Contact the City of Kannapolis to determine the required size of RCP/HP pipe that must be installed 704-920-4221.
5. This permit allows one inspection for each of the five (5) required inspections. **For each failed inspection, there will be a \$50.00 reinspection fee that must be paid through Citizen Access before the reinspection can be performed.**
6. By signing below, I here indemnify and save harmless the City of Kannapolis from all damages and claims for damage that may arise by reason of this construction.

\_\_\_\_\_  
APPLICANT SIGNATURE

\_\_\_\_\_  
DATE



**Right-of-Way Extension/Service  
Permit Application**

Provide the following information for the construction of facilities in the right-of-way:

Owner/Operator of Proposed Line: \_\_\_\_\_

Contact Representative & Position: \_\_\_\_\_

Address: \_\_\_\_\_

Phone: \_\_\_\_\_ Email: \_\_\_\_\_

Contractor of Proposed Line: \_\_\_\_\_

Address: \_\_\_\_\_

Phone: \_\_\_\_\_ Email: \_\_\_\_\_

Representative & Position: \_\_\_\_\_

Sub-Contractor of Proposed Line: \_\_\_\_\_

Address: \_\_\_\_\_

Phone: \_\_\_\_\_ Email: \_\_\_\_\_

Representative & Position: \_\_\_\_\_

List Additional Sub-Contractors and Their Information on Back of Page.

List All Road Rights-of-Way (City and NCDOT) and/or City Easements Where Installation/Construction is Proposed:

\_\_\_\_\_  
\_\_\_\_\_

Type of Utility/Extension Service: \_\_\_\_\_

Diameters	Materials	Length of Pipe

The following requirements and conditions apply to entities requesting installation/construction within rights-of-way/easements within Kannapolis city limits and where Kannapolis utilities are located (this includes NCDOT roadways/rights-of-way and Kannapolis roadways/rights-of-way):

1. The contractor shall contact the City of Kannapolis Engineering Department, 704-920-4200, prior to beginning work within the city limits in order to have an inspector assigned to the project. A preconstruction conference is required between the contractor and all sub-contractors with the City's Inspector.
2. The Owner, Operator and/or Contractor shall be responsible for any repairs necessitated by damage that is caused to roadways, sidewalks, landscaping, utilities and all areas within the City of Kannapolis and/or NCDOT rights-of-way or property to the satisfaction and at the direction of the Director of Engineering.
3. The City of Kannapolis Land Development Standards Manual (LDSM) shall be followed.
4. Directional boring under roadway crossings shall be a ten (10) foot minimum depth under roadways. Also, directional boring shall be at a four (4) foot minimum depth below ground surface.
5. All other boring procedures shall be at a four (4) foot minimum depth under roadways and below ground surface.
6. The following clearance from the outside wall of any structure, footing or pipe culvert (including tunnels, water lines, sanitary sewer lines, and storm lines) is required:
  - a five (5) foot horizontal clearance from the outside wall; or
  - a five (5) foot vertical clearance with a two (2) foot horizontal clearance from the outside wall
7. Provide videos of the installation areas (rights-of-way and easements) before and after construction to the City's Inspector, to determine damage to areas impacted during construction.
8. Any sidewalk damaged during construction of the lines shall have the entire panel removed and replaced as part of the repair. Partial repairs of panels shall not be permitted.
9. The City of Kannapolis Standard Drawing, "Utility Cut Pavement Repair, #109" shall be used for pavement patching. The City of Kannapolis Standard Drawing, "Concrete Sidewalks, #117" shall be used for concrete sidewalk repair. The City's Inspector assigned to the project will provide additional standard drawings that apply to the project.
10. A pre-pour and/or pre-paving meeting and subgrade check with the City's Inspector will be required prior to any concrete pours and/or asphalt placement.
11. The use of City water to perform construction activities shall be metered per Land Development Standards Manual Chapter 1 A. General Note 9.
12. As-built drawing, CAD file, shape files, and/or boring logs shall be submitted to City within thirty (30) days upon completion of project.
13. Work hours are between 7am to 5pm on weekdays. Work shall not be performed on weekends (Saturday-Sunday) or on City observed holidays.

The Director of Engineering may impose additional and reasonable conditions upon the granting of any permit. In the case of noncompliance with these conditions, City reserves the right to stop all work until the facility has been brought into compliance or removed from the right-of-way/easement at no cost to City.

**Applicant Authorized Representative Acknowledgement:**

I have read and understand this right-of-way extension/service permit and the requirements placed upon the Owner/Operator/Contractor/Sub-Contractor. I agree to the conditions listed above to the best of my ability and will fulfill the requirements placed upon this permit application. I certify that all of the information presented in this permit application is accurate to the best of my knowledge.

Printed Name, Title	Signature	Date
---------------------	-----------	------

**City of Kannapolis Use Only**

**This Right-of-Way Extension/Service Request is:**

- Approved** (A copy of this permit showing evidence of approval by City shall be made available at all construction sites for this project. City reserves the right to stop all work unless evidence of approval can be shown.)
  - With the following conditions: \_\_\_\_\_
- Revise and Resubmit**
  - Provide the following: \_\_\_\_\_
- Rejected**

Printed Name, Title	Signature	Date
---------------------	-----------	------

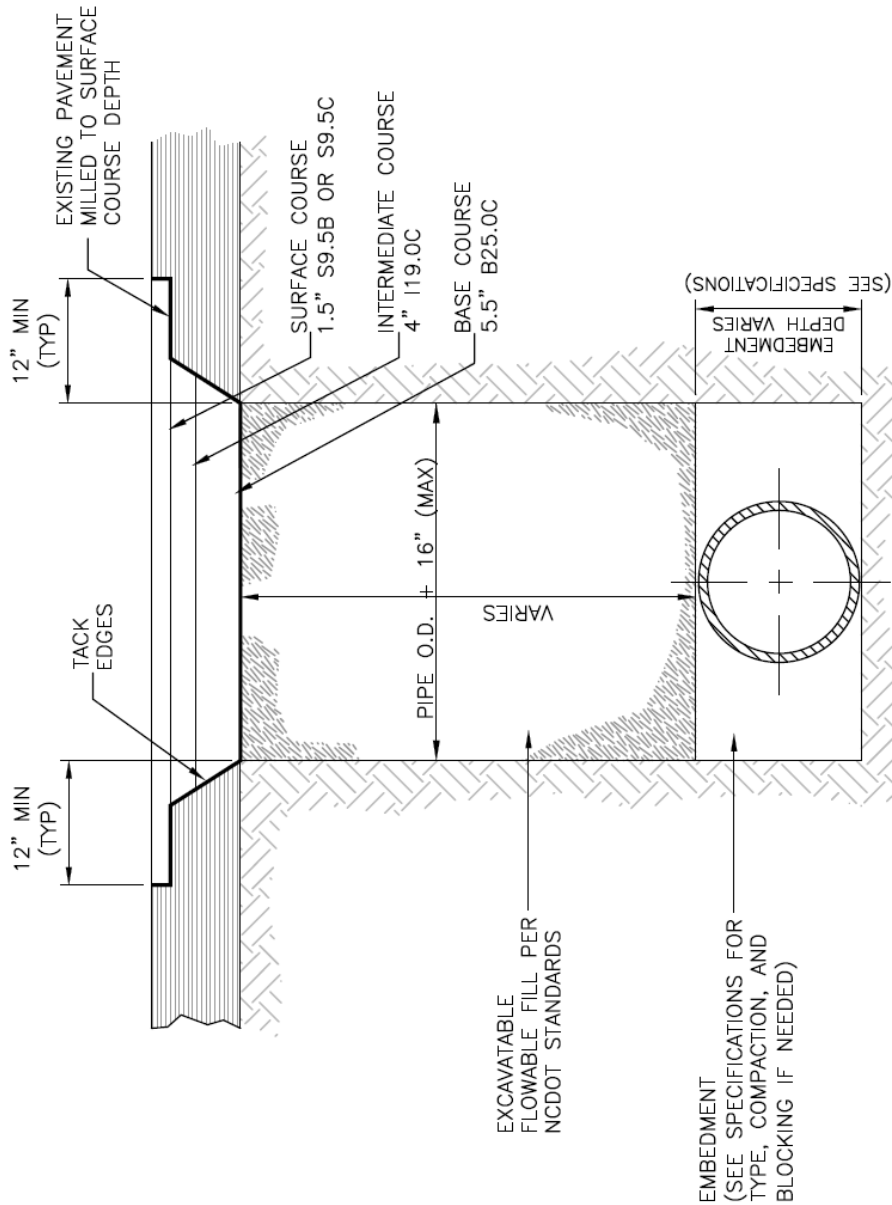

NOT TO SCALE

**UTILITY CUT PAVEMENT REPAIR DETAIL**



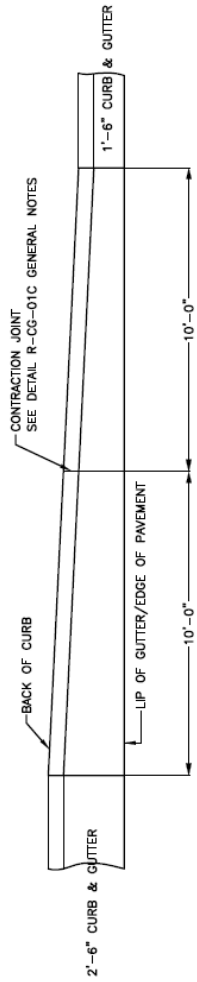

PLAN VIEW  
CURB TRANSITION  
2'-6" CURB & GUTTER TO 1'-6" CURB & GUTTER

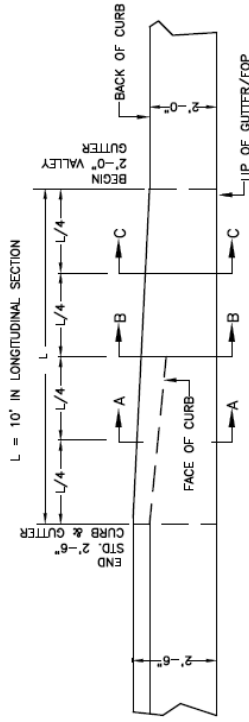
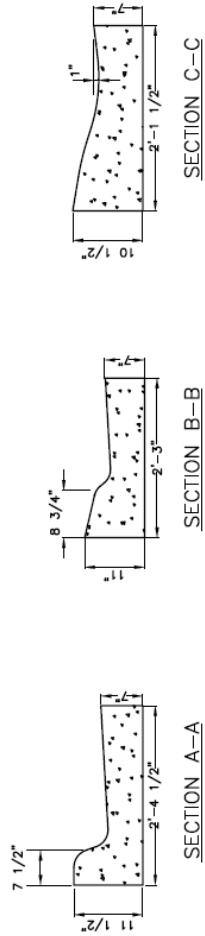

PLAN VIEW  
CURB TRANSITION  
2'-6" CURB & GUTTER TO 2'-0" VALLEY GUTTER

NOT TO SCALE

## CURB TRANSITIONS



JANUARY 2025

117

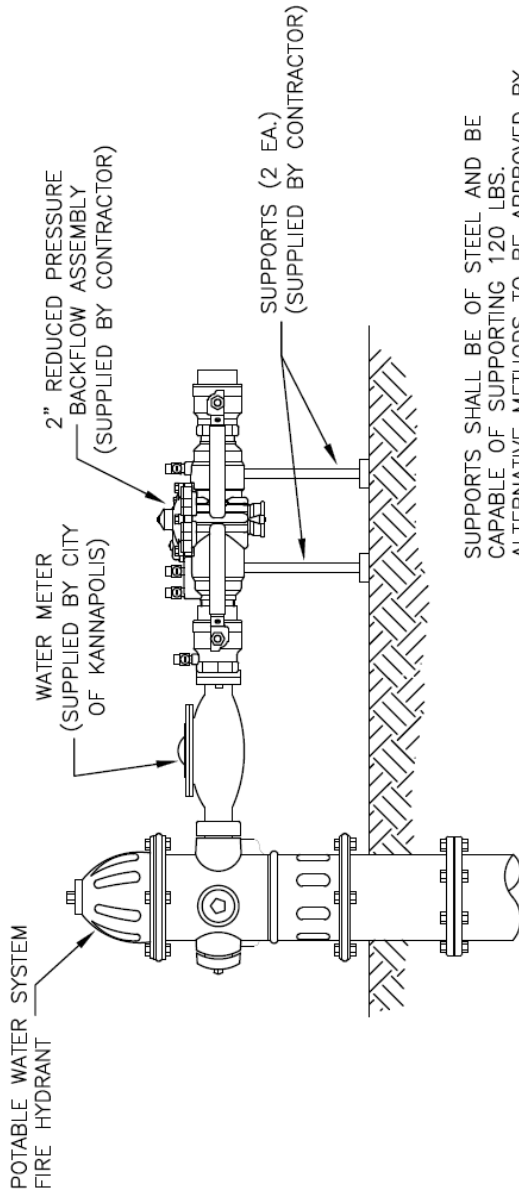

SUPPORTS SHALL BE OF STEEL AND BE CAPABLE OF SUPPORTING 120 LBS. ALTERNATIVE METHODS TO BE APPROVED BY CITY OF KANNAPOLIS BACKFLOW ADMINISTRATOR.

**NOTES:**

1. THE CONTRACTOR MUST INSTALL A REDUCED PRESSURE PRINCIPLE BACKFLOW PREVENTION ASSEMBLY (RP) IMMEDIATELY AFTER THE HYDRANT METER IS SET.
2. BACKFLOW ASSEMBLIES MUST BE TESTED BY A CERTIFIED TESTER PRIOR TO USE.
3. PRIOR TO USE AN INSPECTION BY THE CITY IS REQUIRED FOR ALL HYDRANT METER BACKFLOW PREVENTION ASSEMBLIES.
4. EACH TIME THE HYDRANT METER BACKFLOW PREVENTION ASSEMBLY IS RELOCATED IT MUST BE TESTED.
5. THE CONTRACTOR WILL BE BILLED TO REPLACE AND INSTALL ANY PARTS NOT RETURNED WITH HYDRANT METER.
6. HYDRANT, BACKFLOW ASSEMBLY, AND METER SHALL BE ADEQUATELY INSULATED TO PREVENT FREEZING.
7. HYDRANT WRENCH ONLY, NO PIPE WRENCH ALLOWED
8. SEE CITY OF KANNAPOLIS LAND DEVELOPMENT STANDARDS MANUAL APPENDIX B FOR LIST OF APPROVED PRODUCTS.

NOT TO SCALE

**REDUCED PRESSURE PRINCIPLE  
BACKFLOW PREVENTION ASSEMBLY FOR  
HYDRANT METERS**



## APPENDIX B

### APPROVED PRODUCTS LIST FOR WATER MAIN MATERIALS

Product shall be chosen from the list below or be domestic made. Alternate materials subject to Kannapolis Engineering department review and approval.

#### Pipe

2" – 4" PVC, SDR 13.5, Class 315

6" – 12" PVC, C-900, DR 14, Class 200

3" – 12" DIP, Class 350

16" DIP +, Class 250

¾" – 2" Water Service, Type K Copper

#### Saddles

2" pipe

- Ford S-70 Hinged
- McDonald 3891
- Mueller 13000 series

6" pipe and larger

- Mueller DR2S
- Ford FCD202
- Romac 202NS
- McDonald 4855A

#### Tapping Sleeves

New Branch line equal diameter as existing main

- Mueller H-615
- American Flow Control Series 2800

New Branch line smaller than existing main.

- Mueller H-304
- Romac SST

#### Corporation Stop

- Mueller B-25008N
- Ford FB1000-XX-Q-NL
- McDonald 74701BQ

#### 1" Tee

- Mueller H-15381N
- Ford T444-XXX-Q-NL
- McDonald 74760Q

#### 1" Ball Valve

- Mueller B-25209N
- Ford B44-XXXW-Q-NL
- McDonald 76100WQ

#### Reducer

- Mueller H-15403N
- Ford C44-XX-Q-NL
- McDonald 74758Q



## Meter Stop

- Mueller B-24273N
- Ford BA94-XXXW-Q-NL
- McDonald 74642BYQWW

## Expansion Handwheel

- Mueller H-14234
- McDonald 714-2EHG
- McDonald 714-4EHG
- Ford ECL-XX-NL

## Yoke

- Mueller H-5020
- Ford Y502
- McDonald 14-2
- Mueller H-5040
- Ford Y504

## Straight Check Valve

- Mueller H-14247N
- Ford HS91-XXX-NL
- McDonald 711-3

## 1.5" - 2" Coppersetter

- Ford 70 Series
- Mueller B-2423-2N

## Valve Boxes

- Tyler Union 6855 Slip Type Domestic
- East Jordan 8555 Slip Type Domestic

## Water Meter Box

TriCast 1118 Kannapolis with locking lid

- 3/4" – 1" meters

2'x3'x31" concrete meter box & lid

- 1-1/2" — 2" meters

84"x72"x72" concrete meter box

- 3" - 4" meter
- Bilco JD-AL H-20 aluminum Double Leaf Access Door
- Halliday Products Series H2C

84"x96"x72" concrete meter box

- 6" meter
- Bilco JD-AL H20 - aluminum Double Leaf Access Door
- Halliday Products Series H2C

## Irrigation Box

Southeastern MB-9 with Cast Iron Lid

## Meters

All meter sizes should supply the V4 TTL.

- 3/4" - Hersey Bronze Body RDM Meter 5/8" x 3/4" with NICOR connector and MI. Node 6 AMI module with NICOR Connector
- 1" - Hersey 452 PD meter with NICOR connector and MI. Node 6 AMI module with NICOR Connector
- 1-1/2" - Hersey 562 Bronze body meter with NICOR connector and MI. Node 6 AMI module with NICOR Connector or Kamstrup 3200 SS body with NICOR connector and MI. Node 6 AMI module with NICOR Connector
- 2" - Hersey 572 Bronze body meter with NICOR connector and MI. Node 6 AMI module with NICOR Connector or Kamstrup 3200 SS body with NICOR connector and MI. Node 6 AMI module with NICOR Connector
- 3" - Hersey MVR350 Magnetic Vertical Turbine Meter with NICOR connector and MI Node 6 AMI module with NICOR connector or Kamstrup 3200 SS body with NICOR connector and MI. Node 6 AMI module with NICOR Connector
- 4" - Hersey MVR650 Magnetic Vertical Turbine Meter with NICOR connector and MI Node 6 AMI module with NICOR connector or Kamstrup 3200 SS body with NICOR connector and MI. Node 6 AMI module with NICOR Connector
- 6" - Hersey MVR1300 Magnetic Vertical Turbine Meter with NICOR connector and MI Node 6 AMI module with NICOR connector or Kamstrup 4200 SS body with NICOR connector and MI. Node 6 AMI module with NICOR Connector

## Fire Hydrants

- Mueller — Super Centurion 200
- American Darling — 5-1/4" B-84-B-5
- Clow — Medallion F-2545
- American Darling — 6' B-84-B-5

## Resilient Seated Gate Valves

- Mueller — A-2362 RWGV
- Clow — C-509
- Kennedy — C-509
- American Flow Control — Series 2500

## 3/4"- 2" Reduced Pressure Principle Assembly (RP)

- Zurn Wilkins 975XL2
- Zurn Wilkins 375XL
- Annes LF4000B
- Conbraco 4ALF-200
- Febco LF860
- Hersey FRP 2
- Watts LF009

## 3"-10" Reduced Pressure Detector Assembly (RPDA)

- Zurn Wilkins 375DA / 375AST
- Zurn Wilkins 475DA
- Annes SOOOS
- Conbraco 4ANLF-700LBF
- Febco LF866
- Febco LF866V
- Hersey 6CM
- Watts 909RPDA

## 3/4"-2" Double Check Valve Assembly (DCVA)

- Zurn Wilkins 950XL
- Ames LF2000B

- Conbraco 4ALF-100
- Febco LF850
- Hersey FDC
- Watts LF007

### 3"-10" Double Check Detector Assembly (DCDA)

- Zurn Wilkins 450DA / 450STDA
- Zurn Wilkins 350DA / 350ASTDA
- Ames 3000SS
- Conbraco 4ALF-600 LBF (3"-8")
- Conbraco 4S-600 (10")
- Febco LF856
- Febco LF876V
- Hersey DDC2
- Watts 709DCDA

### Hot Boxes

- BF Products 232-APD
- BF Products 322-APD
- BF Products 56N-APD
- BF Products 65-APD
- BF Products 78 APD
- BF Products 98 APD

### Air Release Valves

- APCO 200A
- GA Industries Series 920
- Miltiplex Crispin PL series

### Combination Air and Vacuum Valve

- APCO 140C
- Multiplex Crispin UniversalAir Release Valves UL series

### Wedge Action Retainer Glands

Approved for 350-psi through 12" and 250-psi through 48". UL/FM approved through 12". All retainer glands shall be epoxy coated or polyester powder coated.

- EBAA – Mega-Lug
- Romac – RomaGrip
- Tyler Union – TUFGRIP TLD

### Wide Range Restrained Fitting

Approved for 350-psi through 12". Coupling/End Cap/Flanged Coupling

- Romac - ALPHA

Approved for 350-psi through 16". Coupling/End Cap/Flanged Coupling

- Krausz USA – Hymax Grip

### Sampling Stations

Approved for 200 psi. All piping shall be stainless steel.

- Kupferle – Eclipse #88-SS

## Transition Coupling

Approved for 250 psi. AWWA C219 NSF 61  
Utilize stainless steel fasteners.

Connections between AC and PVC or DIP shall use:

- Romac – Macro HP
- Ford – FC2W

Connections between PVC or DIP shall use:

- Romac – Macro HP
- Ford – FC2W

Approved for 250 psi. AWWA C219 NSF 61  
Utilize stainless steel fasteners.

- Romac – XR-501 or Macro HP or ALPHA (ALPHA connections between Cast Iron, PVC or DIP only)
- Ford – FC2W